

Telecommunication Networks and Services

Mobile networks 2.

Gusztáv Adamis

BME TMIT

2015





Content



- 1. Introduction
 - Voice digitalisation
- 2. Access to IP networks through telecommunication and cableTV networks
- 3. Switching
- 4. **Mobile networks** ←
- 5. Signalling

Mobile telecommunication systems

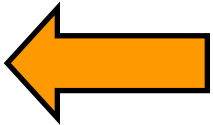
- Overview of mobile networks
- First generation mobile networks
- GSM (2G) 
- **UMTS (3G)**  
- Satellite mobile networks
 - (not compulsory)
- Mobile, closed purpose networks
 - (not compulsory)



UMTS



- UMTS: Universal Mobile Telecommunication System
- Goal: a really universal 3G system
 - 1G systems: „not compatible even with themselves”
 - 2G: still more, incompatible systems
 - 3G: this could not succeed entirely...
- ITU: IMT-2000 (International Mobile Telecommunications-2000) standard
 - UMTS (Eu)
 - FOMA: Freedom of Mobile Multimedia Access (Japan)
 - UMTS compatible
 - CDMA2000: Code Division Multiple Access (US)
- UMTS also has subversions ☹
- 3GPP: 3rd Generation Partnership Project standardises
 - www.3gpp.org

UMTS goals

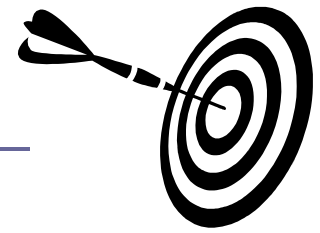

- UMTS goals:
 - better quality of voice (same as in PSTN)
 - better utilisation of spectrum
 - higher data transmission speed
 - backward compatibility with GSM

UMTS services



- Voice transmission:
 - Adaptive MultiRate (AMR) codec (later)
 - 4.7 – 12.2 kbps
- Data transmission, Internet access
 - in cities typically max. 384 kbps, under 120 kmph
 - in rural areas typically max. 144 kbps, 500 kmph
 - in buildings max. 2 Mbps, under 10 kmph
- Multimedia services (next slide)
- Value added services (not only 3G)
 - chat, games, music download, etc.
 - location based services:
 - e.g. where is my girlfriend?, where am I ?!, ATM, pub;
 - emergency call, location based accounting (!)

UMTS services

- UMTS services today in Hungary:
 - voice transmission
 - data transmission
 - video telephony (appr. 100 Ft/minute)
 - TV (70 Ft/minute)
 - e.g. Magyar Televízió, Duna Tv, Echo Tv, Hír Tv, ATV
 - Radio
 - e.g. Petőfi, Kossuth, Sláger, Danubius, Gazdasági Rádió, Klubrádió
 - Traffic monitoring cameras
 - Astoria, Fővám tér, Podmaniczky utca, Gellért tér, Kosztolányi Dezső tér, Margit krt., Roosevelt tér, Csepel
 - Hungarorama ((weather) cameras in several cities)
 - Budapest, Esztergom, Visegrád, Siófok, Győr, Sárvár, Veszprém, Lillafüred, Balatonfüred
 - Download of music, videos
 - Etc, etc.
- But still no „killer application”!!! ☹



Radio interface



- Frequencies:
 - 1885-2025 MHz uplink
 - 2110-2200 MHz downlink
 - reserved for satellite: 1980-2010 MHz up, 2170-2200 MHz down
- Medium access:
 - *CDMA*, Code Division Multiple Access
 - Same frequency, same time, different code
 - like: multilanguage airport waiting hall
 - Every signal is spread in the whole spectrum, but with small power
 - Goal: better utilisation of the spectrum

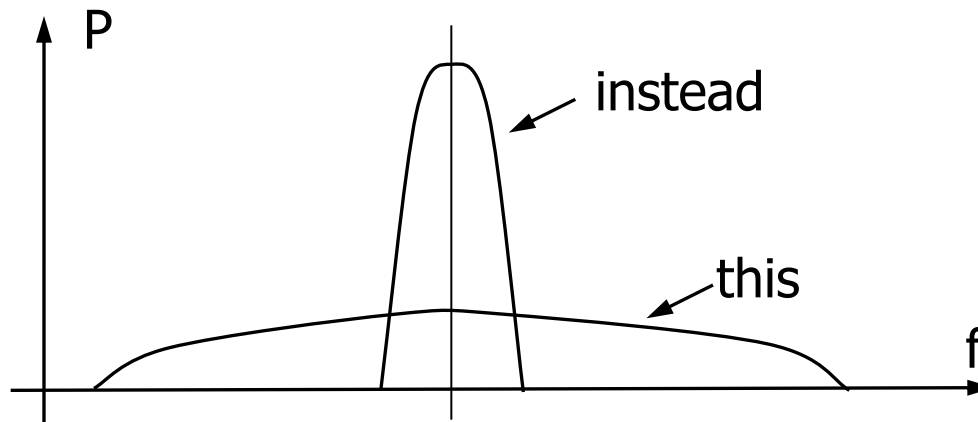

FDMA

Frequency Division Multiple Access

- Orthogonal in frequency within cell
- Narrow bandwidth per carrier
- Continuous transmission and reception
- No synchronization in time

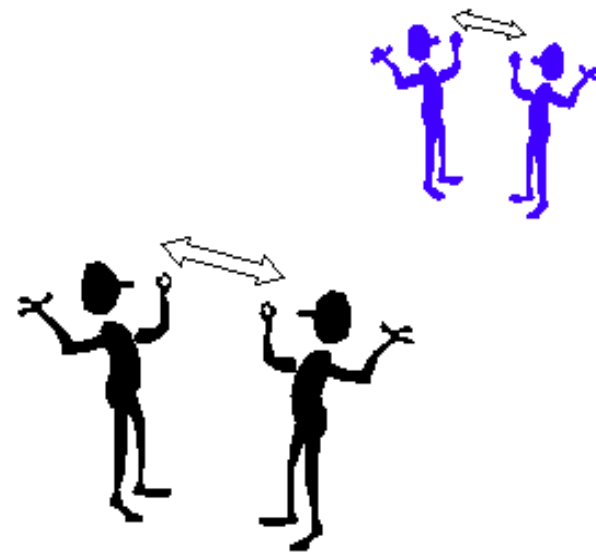
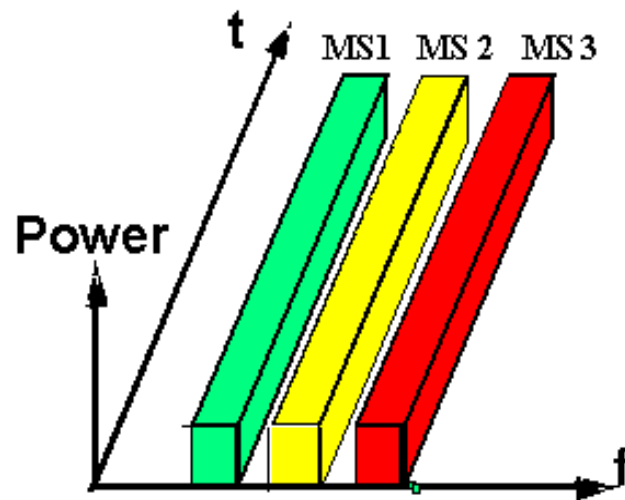

TDMA

Time Division Multiple Access

- Orthogonal in time within cell
- Increased bandwidth per carrier
- Discontinuous transmission and reception
- Synchronization in time

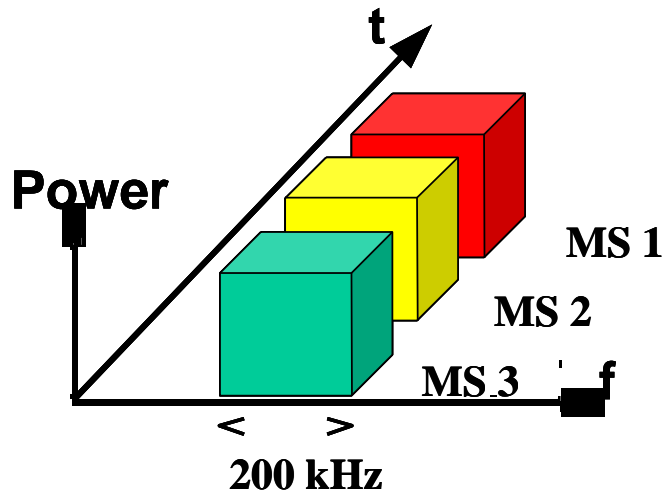

CDMA

Code Division Multiple Access

- Separate users through different codes
- Large bandwidth
- Continuous transmission and reception

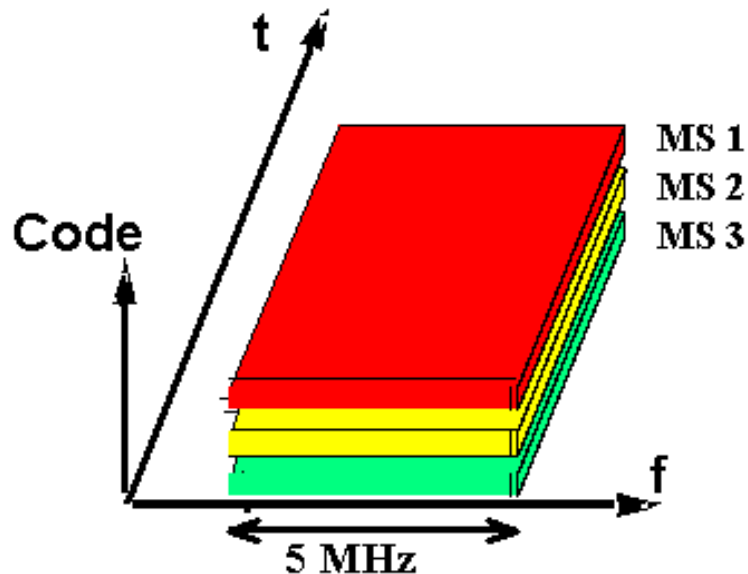

CDMA International Cocktail Party



What can YOU hear/understand...

...if you speak only Japanese?

...if you speak only English?

...if you speak only Italian?

...if you speak only Japanese, but the Japanese-speaking man is at the other corner of the hall?

... if you speak only Japanese, but the Spanish cries loudly?

Japanese

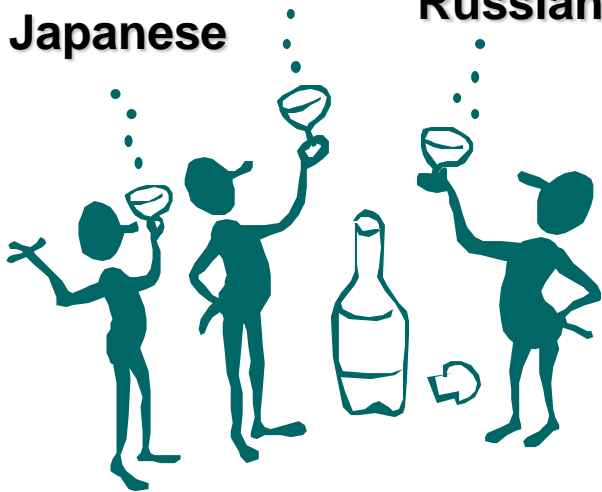

Russian

Spanish



Italian

Code sharing

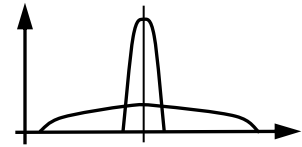

- ❑ The digital signal is multiplied with a so-called spreading code, and the result is to be transmitted
 - multiplication: NOT(XOR(bit1,bit2))
 - transmitted signal is added to the other signals transmitted by other mobiles
- ❑ The bitrate of the spreading code (chiprate) much greater (appr. 100x) than that of the „useful” signal
- ❑ The spreading codes are orthogonal, that is the average of multiplication of any two spreading codes is 0

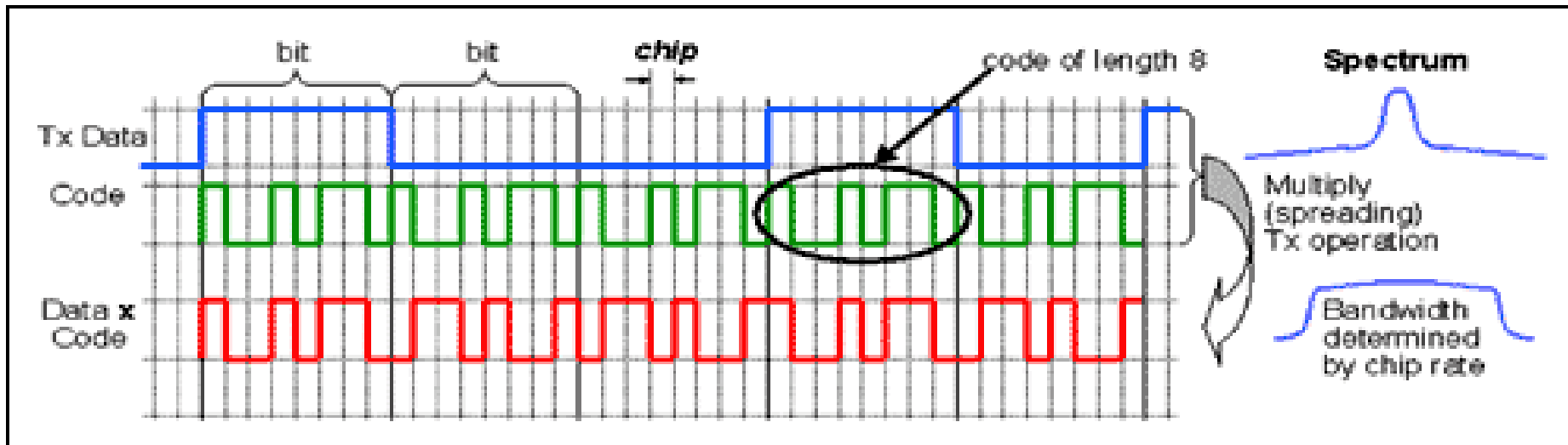

Code sharing

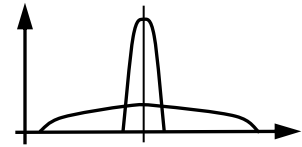

- A bit more detailed:
- Encoding
 - STEP 1. Let us represent the bits of the spreading code and the bits of the data to be encoded in the following way:
 - $1 \rightarrow 1$
 - $0 \rightarrow -1$
 - Recognise: this case NOT(XOR(a,b)) is actually $a*b$
 - $1*1=1, 1*-1=-1, -1*1=-1, -1*-1=1$
 - STEP 2. Let us multiply the spreading code with the data to be transmitted
 - multiply every bit of the spreading code with *one* bit of the data (this way the signal speed increases remarkable)
 - STEP 3. Let us transmit the multiplied signal on the common frequency
 - In our model we simply add all the signals
- Decoding
 - STEP 1. Let us multiply the received signal (sum of STEP 3 of encoding) with the bits of the spreading code of the transmitter. (As many times, as many bits we want to receive.)
 - STEP 2. Let us average the values calculated this way for (data) bit durations
 - STEP 3. If average 1: sent bit 1. If average -1: sent bit 0
 - STEP 4. Let us do this for every receiver

Code sharing

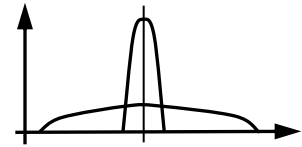

□ Example for encoding:

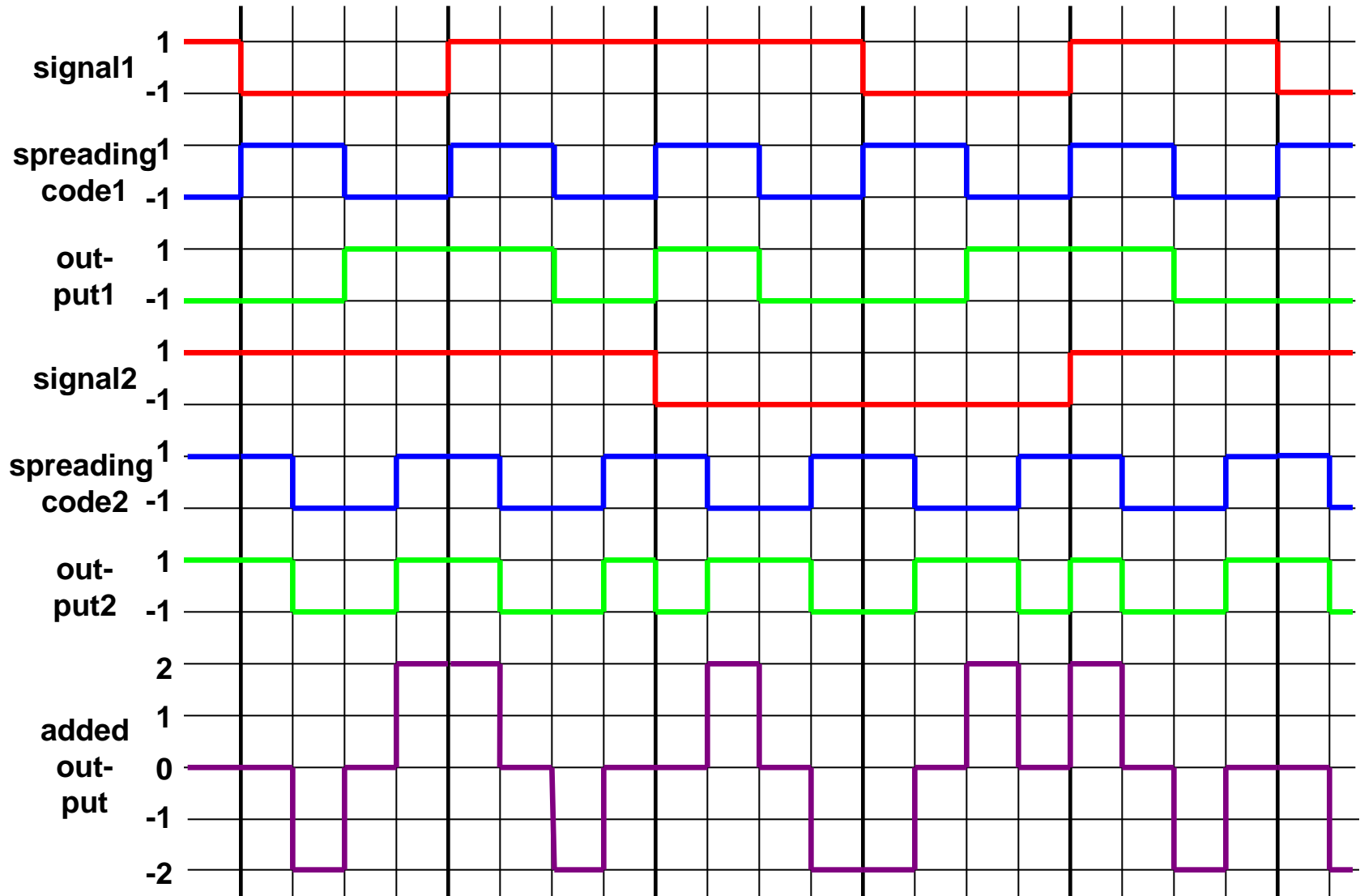

Code sharing

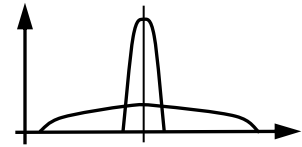

□ Example of decoding:

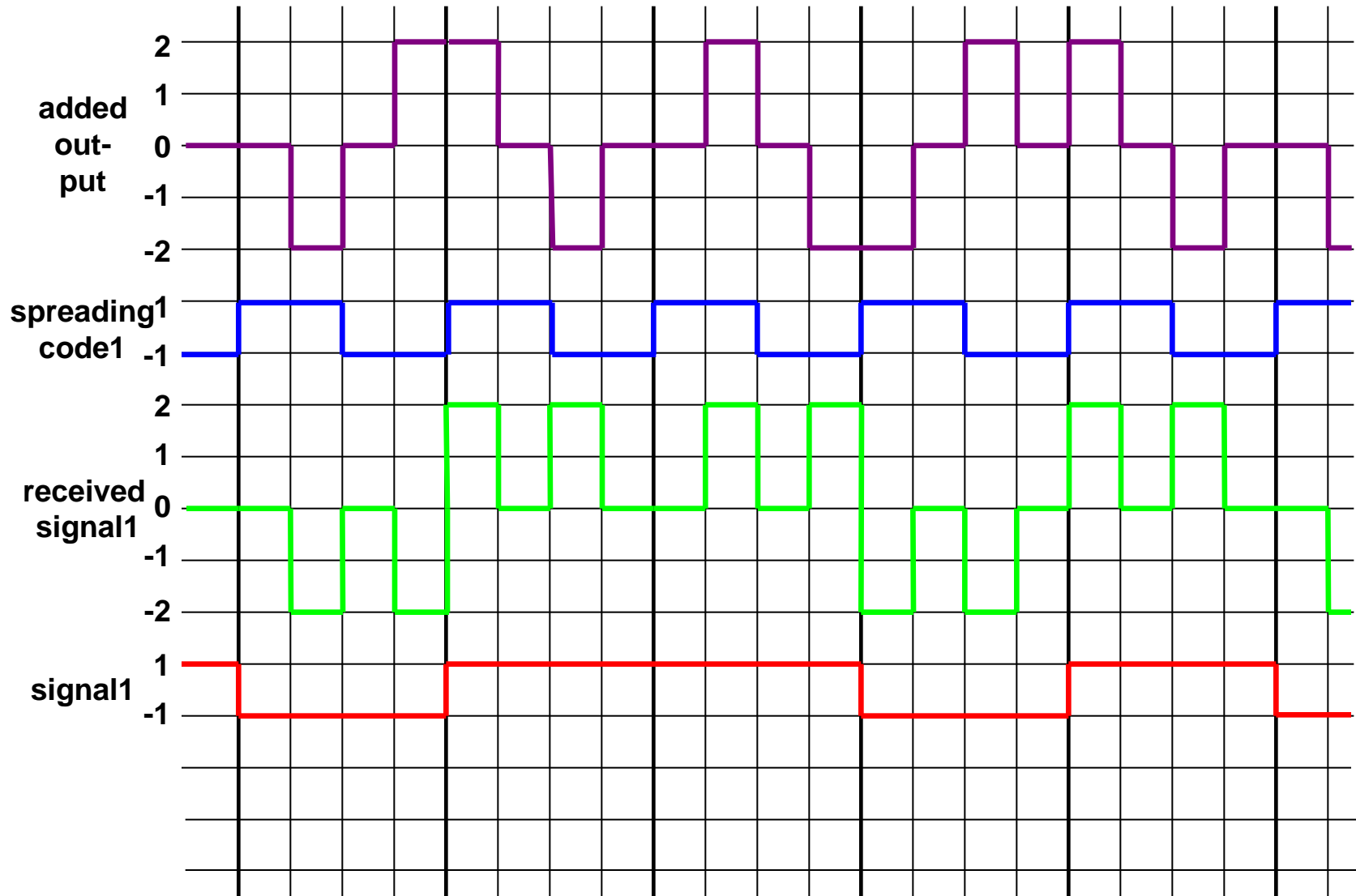

Code sharing

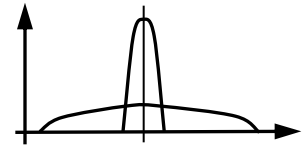

□ Let us see a numerical example!

- Let us transmit the signals $(1, 0)$ and $(1, 1)$ with using the $(1, 1, 0, 0)$, and $(1, 0, 0, 1)$ spreading codes

□ Encoding:

- STEP 1. Data signals are:
 - A: $(1, -1)$
 - B: $(1, 1)$
- STEP 1. The two spreading codes are:
 - A: $(1, 1, -1, -1)$
 - B: $(1, -1, -1, 1)$
- STEP 2. Signals to be transmitted:
 - A: $1, 1, -1, -1, -1, -1, 1, 1$
 - B: $1, -1, -1, 1, 1, -1, -1, 1$
- STEP 3. Sum of them:
 - $2, 0, -2, 0, 0, -2, 0, 2$

□ Decoding

- STEP 1. The multiplication:
 - A: $2, 0, 2, 0, 0, -2, 0, -2$
 - B: $2, 0, 2, 0, 0, 2, 0, 2$
- STEP 2. Averages:
 - A: $1, -1$
 - B: $1, 1$
- STEP 3. Received signals:
 - A: $1, 0$
 - B: $1, 1$

- Comment: we could do this, because the spreading codes are really orthogonal, that is the average of the multiplication of the two spreading codes is really 0:

- The multiplication of the two spreading codes: $1, -1, 1, -1$
- The average: 0

Spreading code generation

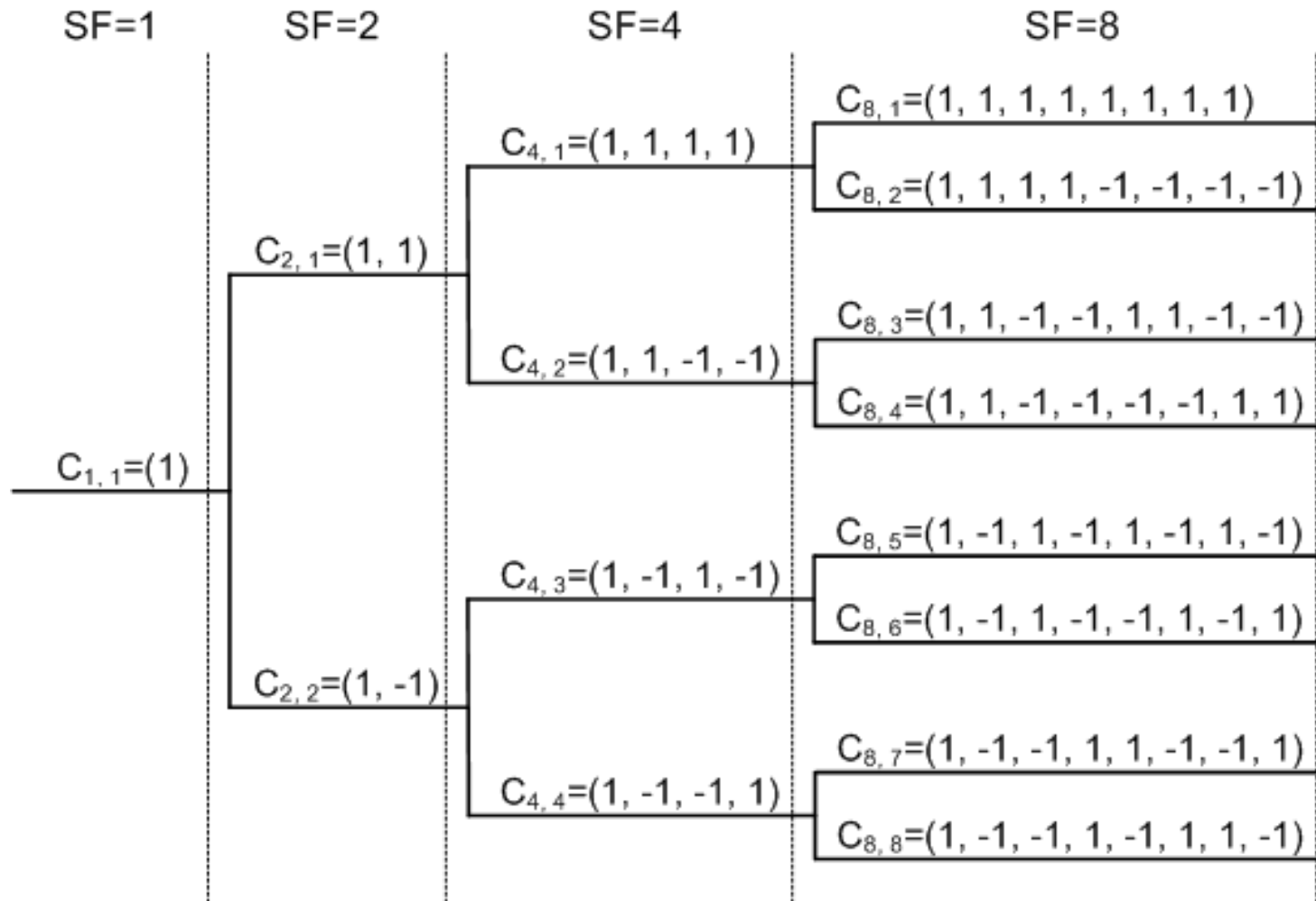

GSM/GPRS architecture („2,5G”)

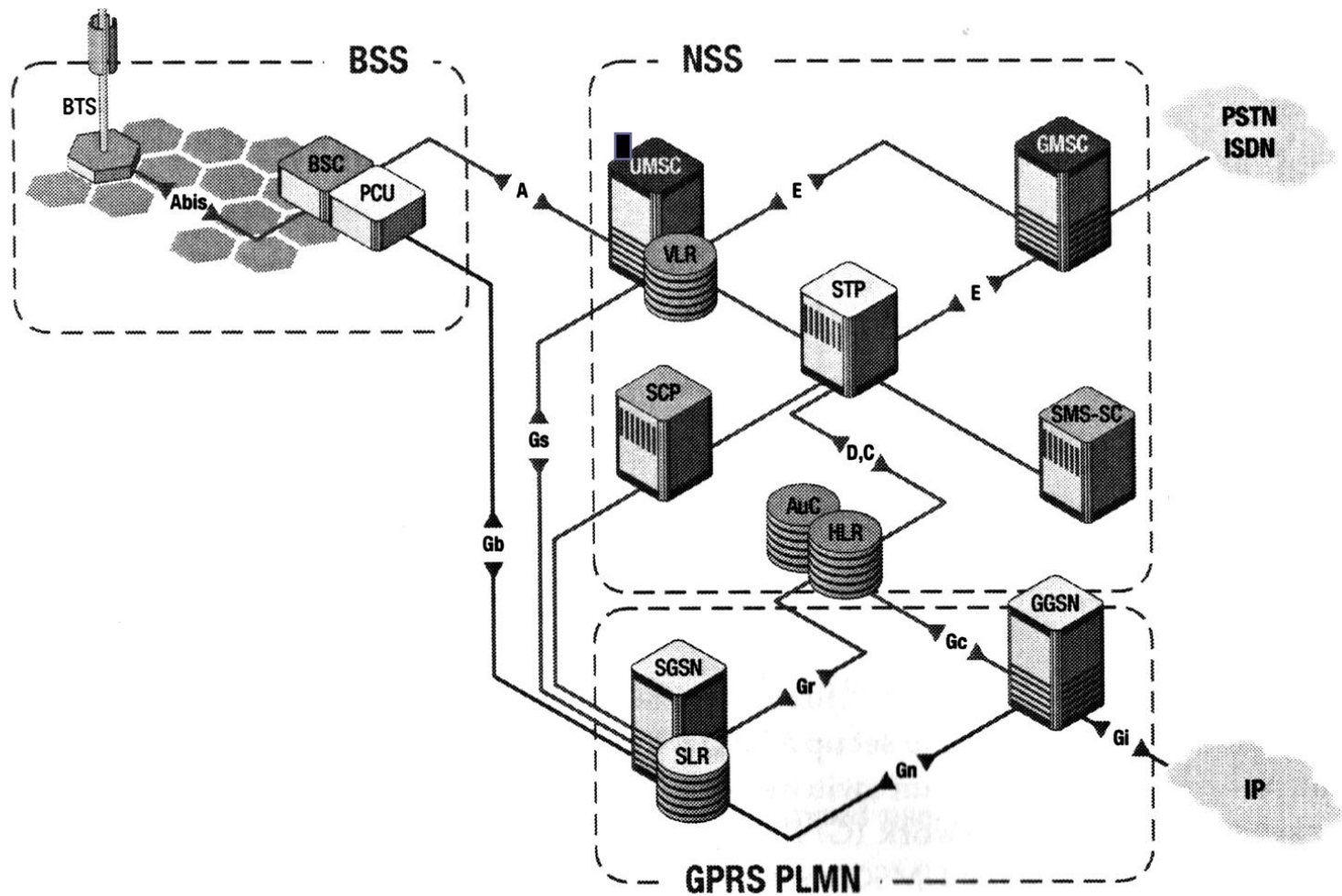

UMTS R'99 architecture

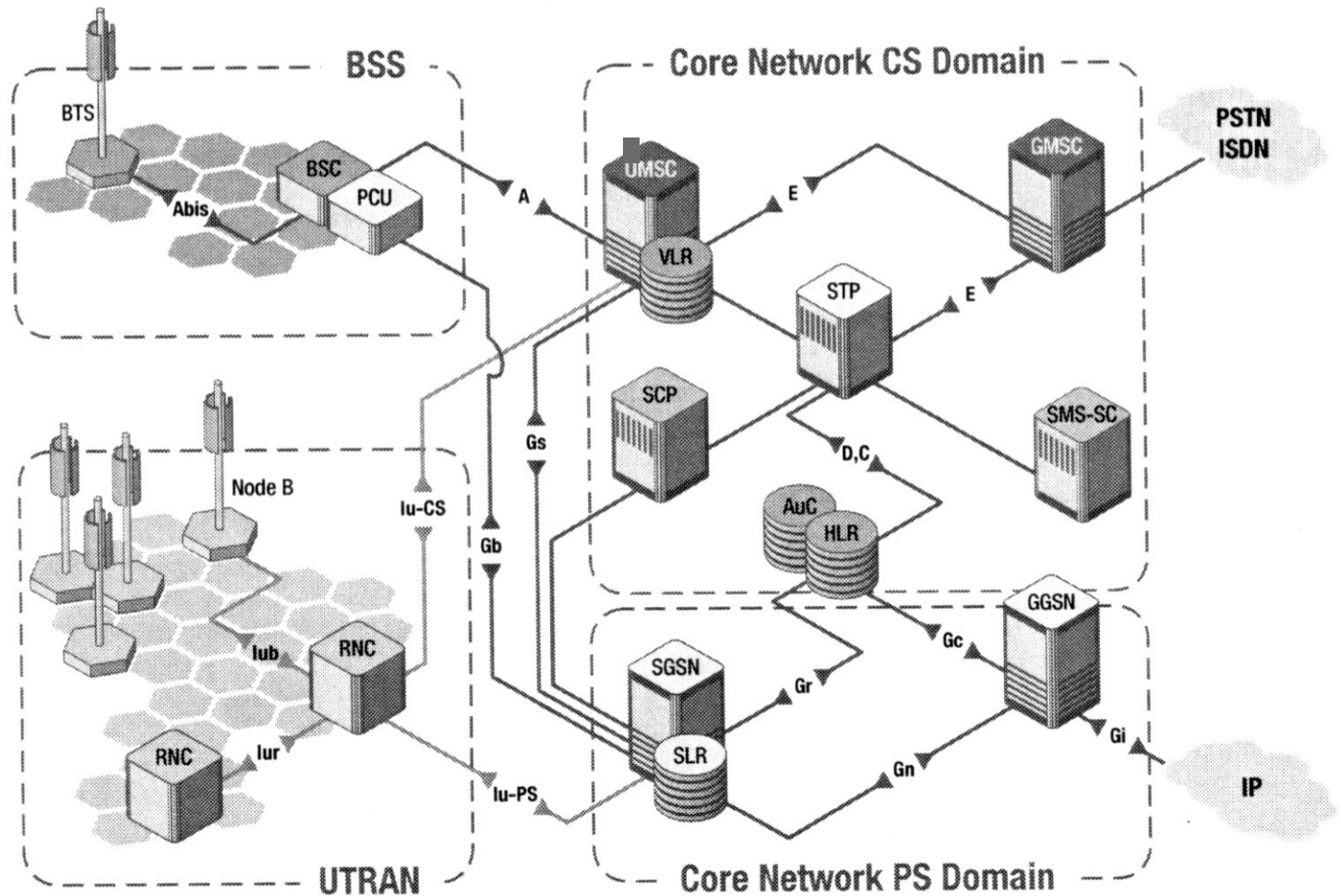

UTRAN: Universal/UMTS Terrestrial Radio Access Network

The UMTS network

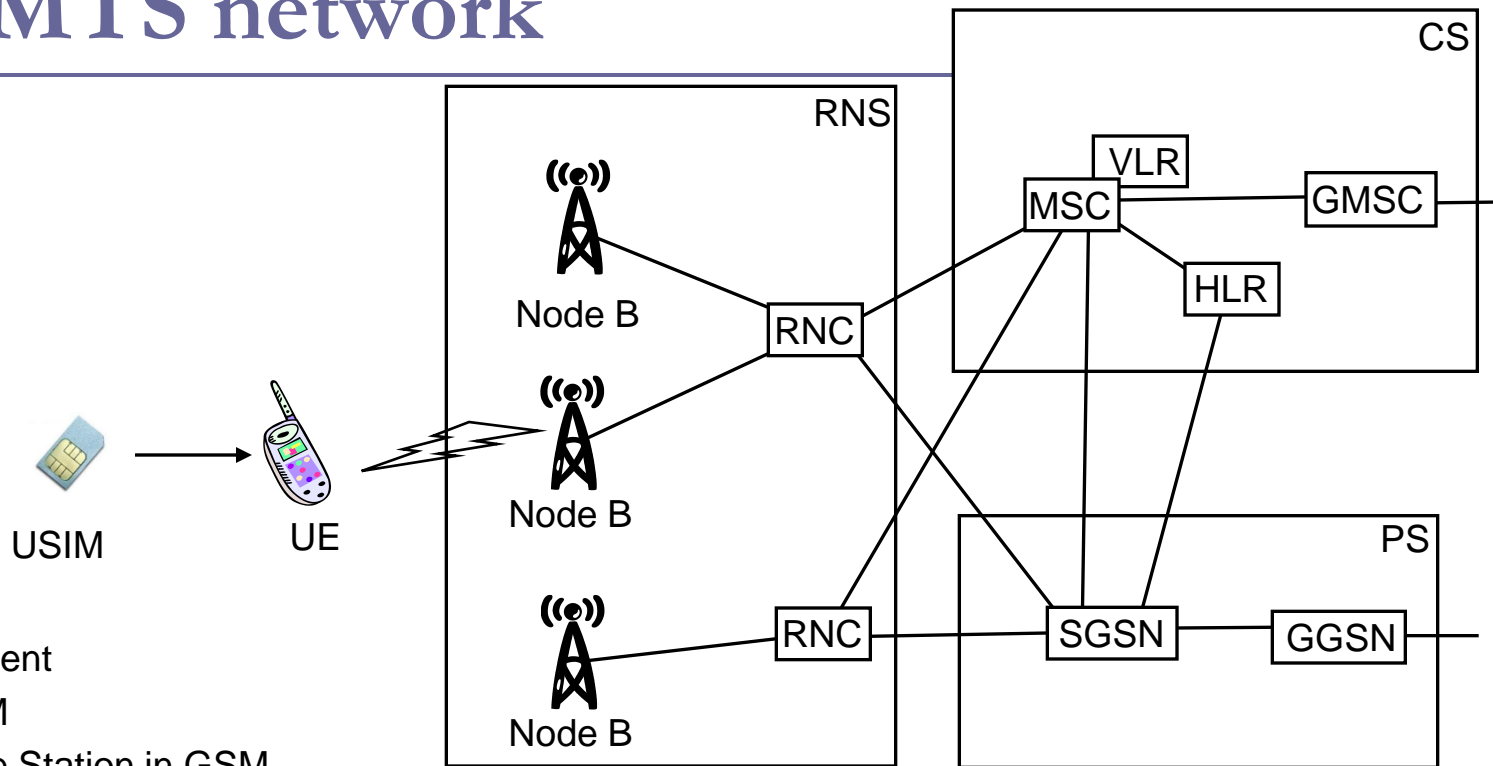

UE: User Equipment

USIM: UMTS SIM

Node B: like Base Station in GSM

RNC: Radio Network Controller, (like BSC in GSM)

RNS: Radio Network Subsystem

MSC, HLR, VLR: same as in GSM

GMSC: Gateway MSC: MSC and gateway to other network(s) (e.g. ISDN)

CS: Circuit Switched subsystem

SGSN: Serving GPRS Support Node

GGSN: Gateway GPRS Support Node: packet switch and gateway to other network(s) (e.g. Internet)

PS: Packet Switched subsystem

UMTS Release 99: Core Network ~ GSM+GPRS, Radio IF different

Duplexity management in UMTS



- Task to solve: Separate the up- and downlink data
- The possible solutions:
 - in time
 - in frequency
- Both used in UMTS (but not at the same time)
 - FDD: Frequency Division Duplexing
 - higher frequency in downlink direction (greater attenuation → greater power needed)
 - TDD: Time Division Duplexing
 - advantage: the ratio of the up- and download can be dynamically changed according to the current needs
 - (ping-pong method)

Handover – circuit switched

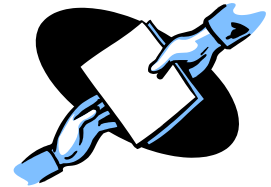

□ GSM: hard handover

- MS communicates with either base station then, in the next time slot with the other one
- the handover is as fast as it can be
- cell change with hysteresis: to reduce the number of handovers in the case when the MS moves at the boundaries of the cells

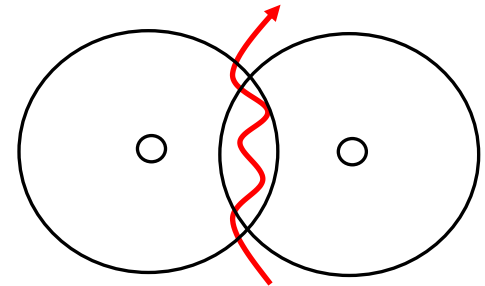

UMTS soft handover

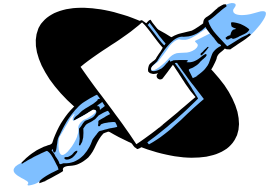

- UMTS: soft handover
 - UE is in contact with more (max. 3) base stations
 - downlink data (the same) is transmitted by all of them – so the UE receives it from several sources
 - so if something is lost from a given base station it can be replaced from the others
 - uplink data (the same) is received by every base station
 - the network assembles the pieces of data received by the different base stations – so if data is lost in a cell it may be corrected by those received in the other cells
 - this connection to several base stations can last a relatively long time
- The redundancy is important, because we are at the edge of the cell, where the receive is the worst
 - but redundant transmission requires a bit of waste of bandwidth
- The code sharing makes it possible:
 - same frequencies in neighbouring cells

UMTS power control



- ❑ The orthogonality of the applied spreading codes is not perfect
- ❑ In a base station when receiving the signal of a UE, the signals of the other UEs appear to be noise
 - (no such a problem in downward direction, since only the Node B transmits)
- ❑ So the signal of every UE must arrive to the Node B with the same power
 - otherwise the strongest suppresses all the others
- ❑ Solution: Node B orders the UEs to reduce/increase the transmission power
- ❑ 1500 times/sec (!)
 - Else e.g. a UE comes out from the shadow of a building (till that time transmitting with great power) will destroy the communication of the whole cell
- ❑ Similar in GSM:
 - to spare batteries, to reduce the physiological risks
 - to avoid interference with far cells using the same frequency
 - 2 times/sec (!)

Power control at soft handover

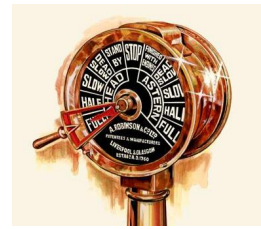

- UE in soft handover may receive different power controlling commands from the different Node Bs:
 - increase/keep/decrease the power
- The rule:
 - If anybody orders to decrease: UE decreases.
 - Otherwise if anybody orders to keep: UE keeps.
 - Otherwise UE increases.
- The idea: To transmit with the minimal power, in order not to destroy the communication in none of the cells. But if UE keeps the rules above it follows that the power will be enough at least in one of the cells.

UMTS cell breathing



- More users in a cell
- → bigger „background noise”
- → smaller is the effective size of the cell
 - the far UE should transmit with larger than the maximal power
- ⇒ the size of the cell depends on the traffic
 - cell is „breathing”
- makes the design of the cell structure more complicated



HSPA (High-Speed Packet Access)

- Improvement of UMTS to higher data transmission speeds
- Common name of 2 protocols:
 - HSDPA (High Speed Downlink Packet Access)
 - up to 14.4 Mbps
 - in Hungary today: 0.6 – 1.3 Mbps
 - <http://index.hu/tech/mobil/hsdpa1005/>
 - HSUPA (High Speed Uplink Packet Access)
 - up to 5.6 Mbps
 - near future
- Higher speed access methods (50-100 Mbps...) are yet under development

UMTS R'99 architecture

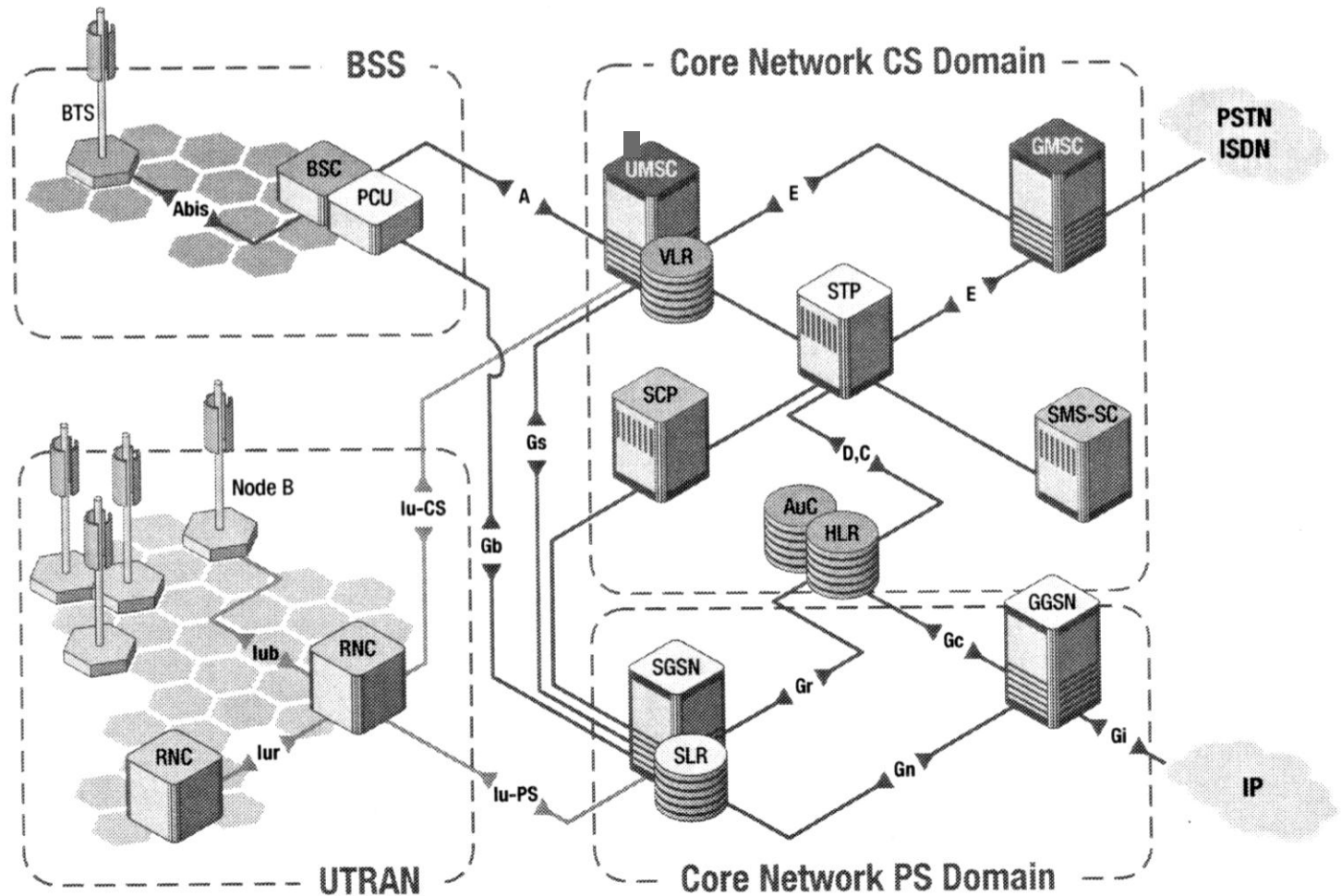

UTRAN: Universal/UMTS Terrestrial Radio Access Network

UMTS R4 architecture

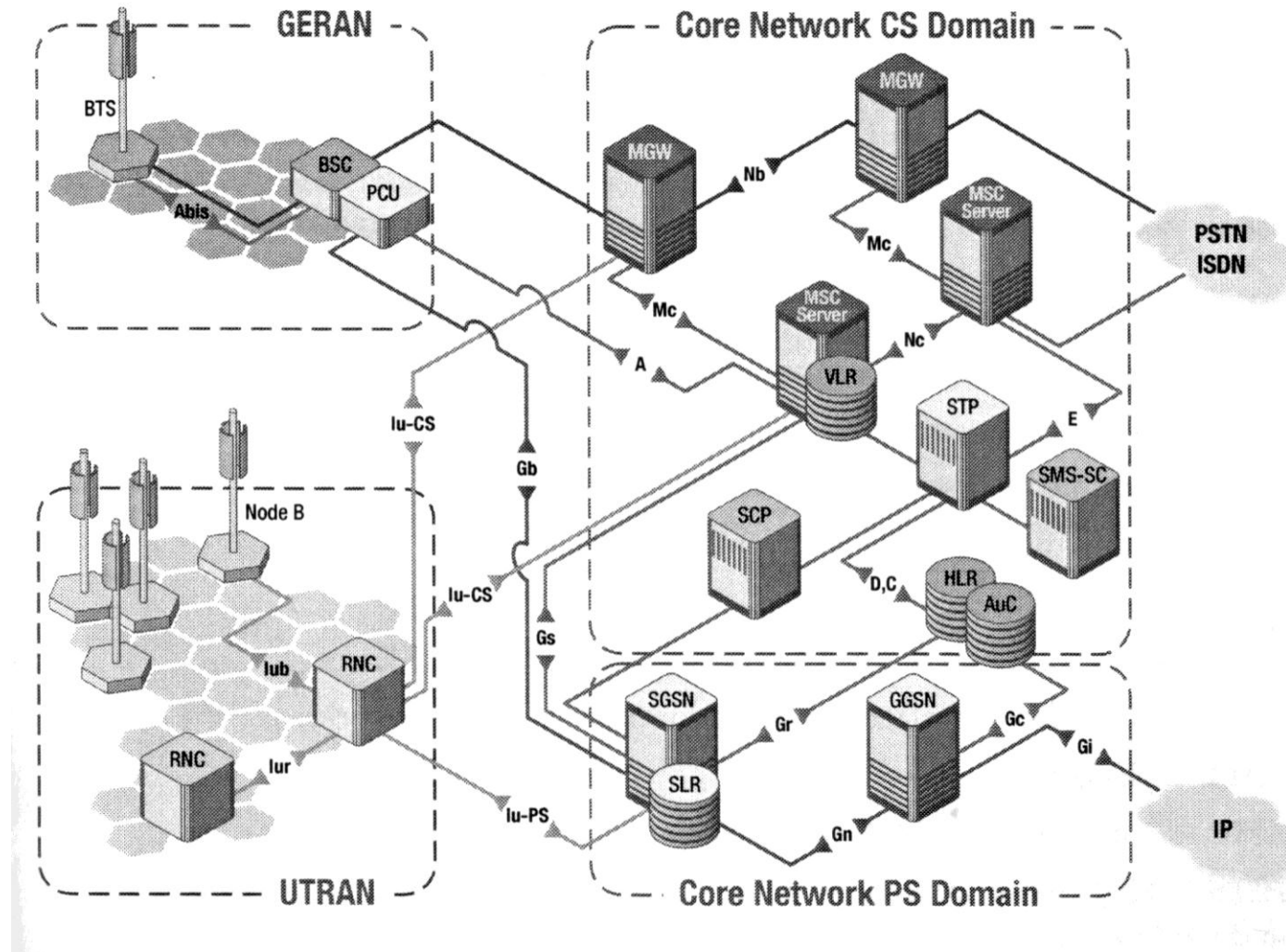

GERAN: GSM EDGE Radio Access Network

Separation of functions of switches

- (G)MSC Server [(G)MSS] is responsible for:
 - Signaling (call control)
 - a mobility management (together with VLR)
- MGW – Media Gateway is responsible for :
 - Transmission of user traffic (voice, data) within core network
 - Protocol conversion towards
 - Radio access network (UTRAN, GERAN)
 - PSTN/ISDN
 - Previous mobile networks (Before Rel 4)
 - Goal: any protocol should be used between MGWs
 - IP or ATM
 - az MGW is actually an ATM switch or an IP router
 - if IP:

UMTS Release 4 – Control/User Plane

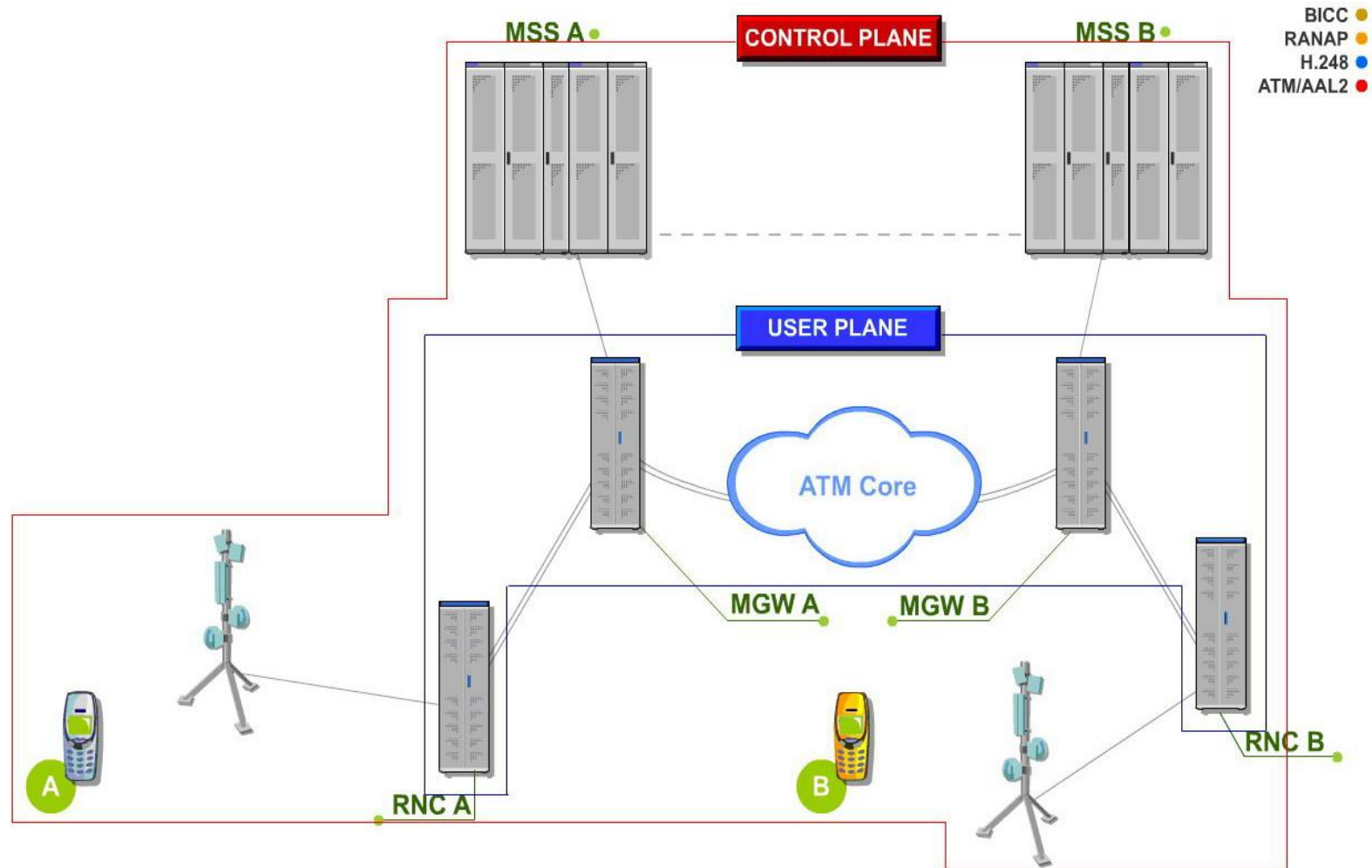

Future: All IP UMTS core network

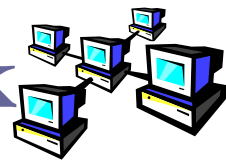

- Current UMTS core: ATM
- Future (?) : All IP core network:
 - Advantages of IP core:
 - More services
 - More flexible
 - Cheaper
 - MGW (VoIP!!) and SGSN can be integrated
 - Disadvantages of IP core:
 - An other conversion is needed
 - Reliability is not yet obvious

Next Generation Networks

- Next Generation Networks, NGN
- Basic idea: Build a *common* core network for different *services*:
 - voice transmission (telephone)
 - videotelephony and other multimedia data transfer
 - television
 - Internet
 - Virtual Private Network, VPN
 - instant messaging (chat)
 - distributed games
 - other, existing and not yet existing services

NGN architecture

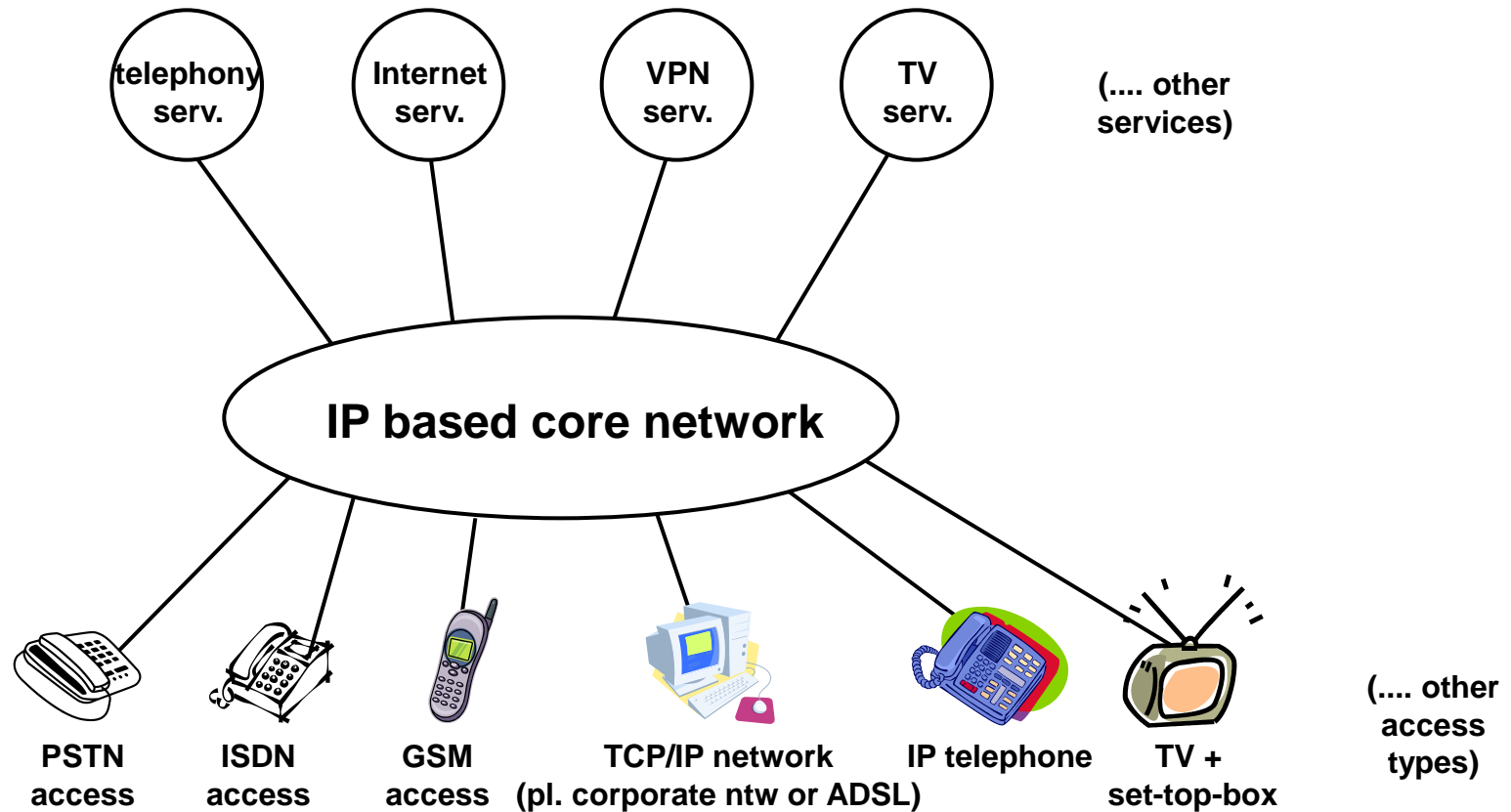

- NGN is a concept, and not a concrete technology

Next Generation Networks

- These services can be reached from:
 - different terminals
 - different access networks
- But the service is the same
- And for each service
 - same core network (transport network)
 - full IP based („all-IP network”)
- E.g. a telephone call may end on the called party's:
 - fixed telephone
 - mobile
 - PC
 - PDA through WLAN
 - depending how the called party has set it
 - independently what the calling party dialled

Mobile telecommunication systems

- Overview of mobile networks
- First generation mobile networks
- GSM (2G)
- UMTS (3G)
- **Satellite mobile networks**
- Mobile, closed purpose networks

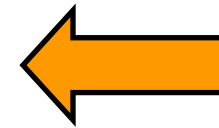

Satellite mobile networks

- „Base Station” on the satellite
- Advantage:
 - great Earth-surface coverage
- Disadvantages:
 - expensive
 - greater delay
 - greater power



Satellite orbitals



- Shape of orbital:
 - circle
 - ellipse (Earth is in one of the focal points)
- Altitude („height”) of orbital:
 - „theoretically” „any”
 - but:
 - must be outside the atmosphere: it brakes
 - hard to determine the „end”
appr. 100 - 1000 km
 - van Allen radiation zones
 - electrically charged particles
 - inner: around 3200 km (proton)
 - outer: around 15.000-19.000 km (electron)
 - too large altitude is unnecessary

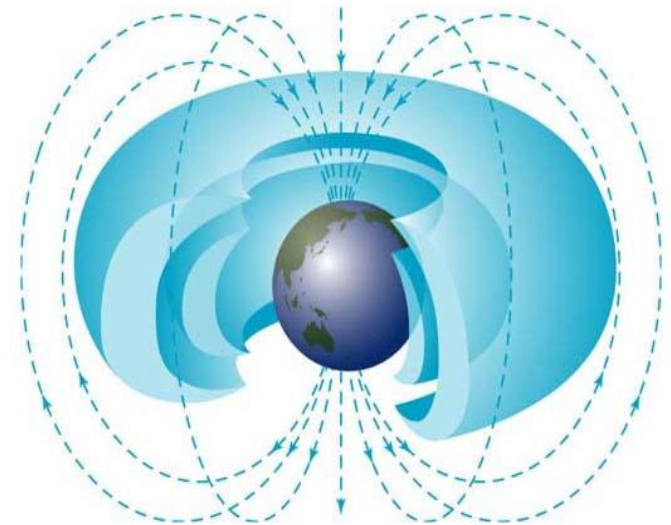

Satellite orbitals



- 3 major altitudes:
- LEO:
 - Low Earth Orbit,
 - 400 - 1500 km
- MEO:
 - Medium Earth Orbit
 - 5000 - 13.000 km
- GEO:
 - Geostationary Earth Orbit
 - 35.785 km (~ 36.000 km)
 - only above Equator (only one!)

Satellite orbitals



- Advantages of the higher altitudes:
 - fewer satellites are enough
- Disadvantages of the higher altitudes:
 - larger delay
 - larger attenuation, larger power
- GEO on the top of all above:
 - no satellite change
 - but: poles are not reachable

- International Maritime Satellite Telecommunication,
 - since 1979
 - later terrestrial, too
- 4 GEO satellites, global coverage
- Different (typically not in hand fit) terminals
 - Voice transmission
 - Data transmission: max. 492 kbps





- Hand-equipments
 - especially for voice
 - data: 2.4 kbps
- 66 satellites
 - global coverage
- 780 km: LEO
- March 2000 (after one and a half year of operation): „bankrupt”
 - terrestrial networks developed fast, poor marketing
 - after 1 year in operation again (with the help of Pentagon)
- Disturbs radio astronomy
 - (frequency used is too close to emission frequency of OH molecule)

- Hand-equipments
 - especially for voice
 - data: 9.6 kbps
- 48 satellites
- 1414 km -- LEO
- Hand equipments – when possible – use terrestrial (e.g. GSM) systems
 - if not, only then satellite
- No satellite-satellite connection:

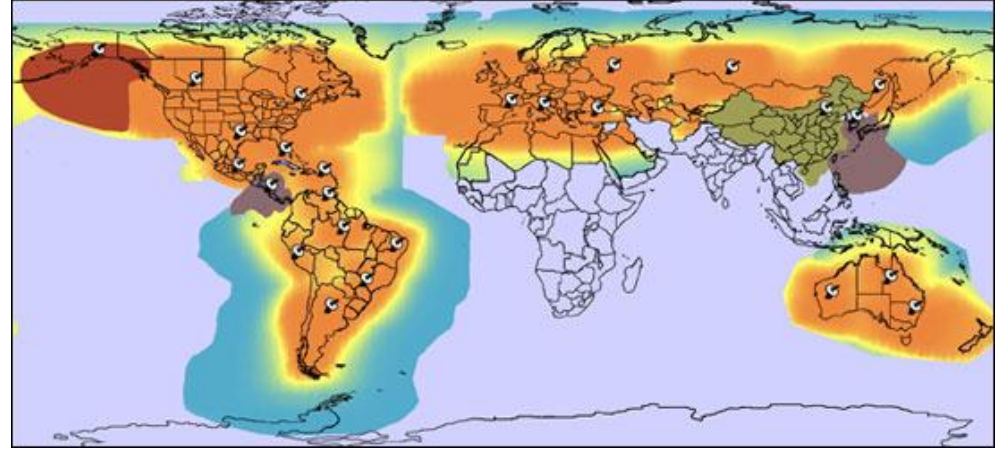

Globalstar



Iridium

- 2001-
- GSM/satellite
- Hand-equipments especially for voice
 - Data: 9.6 kbps, max. 144 kbps – packet switched
- 1 GEO satellite!!!
- Centre: United Arab Emirates
 - covers 99 countries



Mobile telecommunication systems

□ Overview of mobile networks



□ First generation mobile networks



□ GSM (2G)



□ UMTS (3G)



□ Satellite mobile networks



□ **Mobile, closed purpose networks**

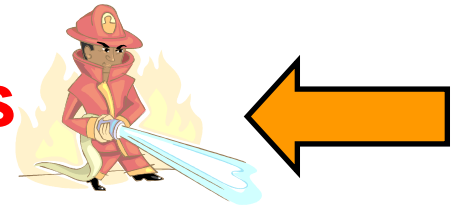

Mobile, closed purpose networks



- For emergency services: fire brigades, police, medical ambulance, disaster recovery, etc.
- (Partly for professional civil applications, e.g. government, logistics)
- Increased needs compared to GSM:
 - smaller call blocking ratio
 - call priorities (urgent calls)
 - dispatcher service
 - group call (automatic reception and speaker service)
 - high reliability
 - high data security

Mobile, closed purpose networks



Also in Hungary:

- TETRA (Terrestrial Enhanced Trunked Radio):
 - Solution of Motorola and Nokia. That proved itself to be the best
 - 380-400 MHz
 - Since December 2006

