

Gyakorlat 1

Moldován István



Budapest University of Technology and Economics



Department of
Telecommunications and Media Informatics

Upstream Scheduling in DOCSIS



BME-TMIT

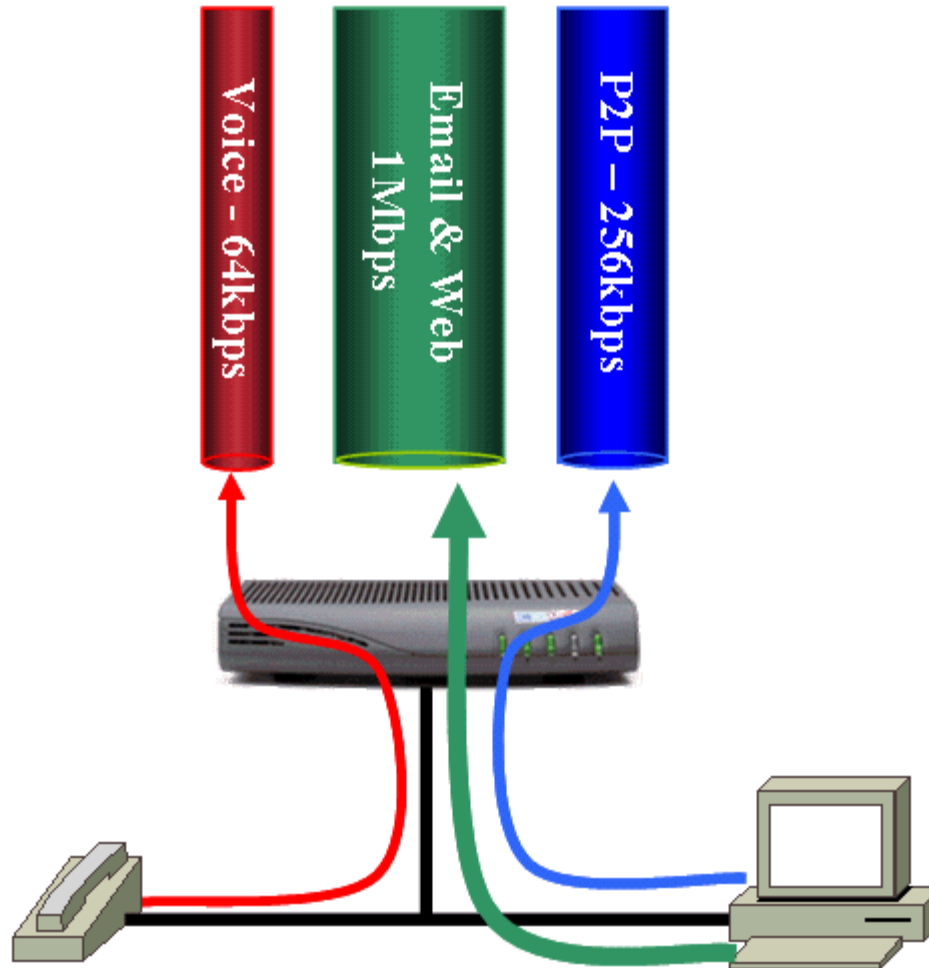

- **Bandwidth Request Backoff and Retry Algorithm**

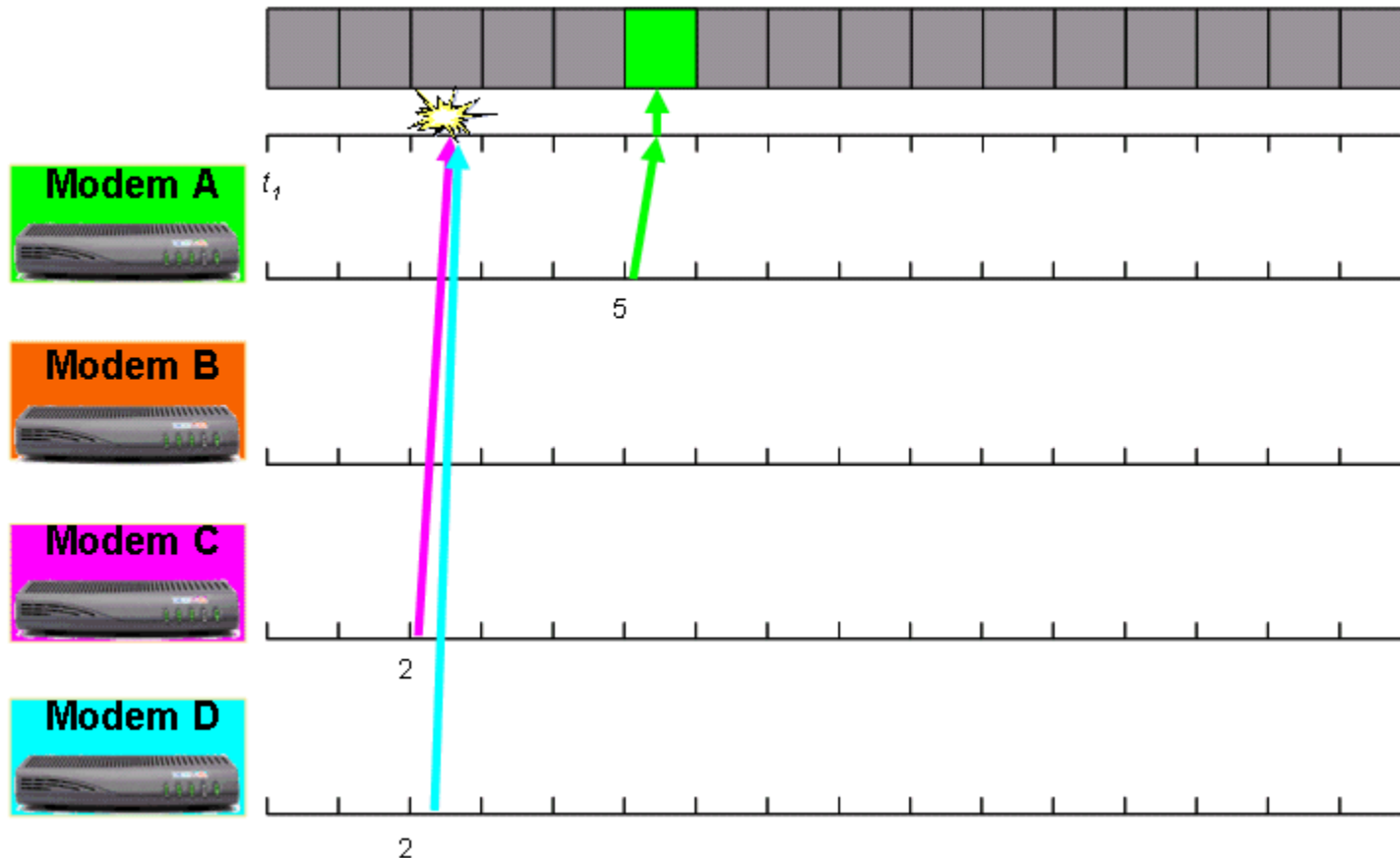

Unsolicited Grant Service

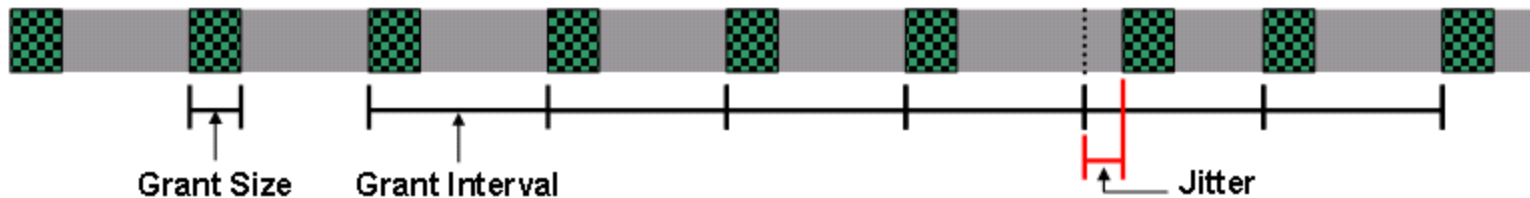

UGS - Előre konfigurált értékek

Realtime polling

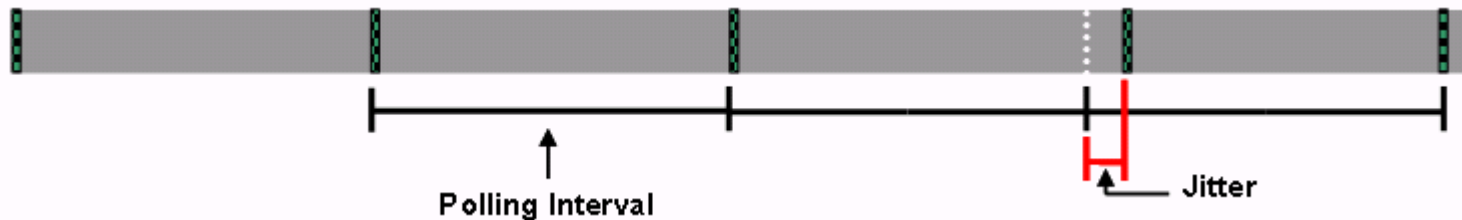

Előre konfigurált lekérdezések

Non Real Time Polling Service (nRTPS)

Hasonló mint a realtime, de nincsenek fix lekérdezési időpontok

- 1. lépés: UGS kiosztása

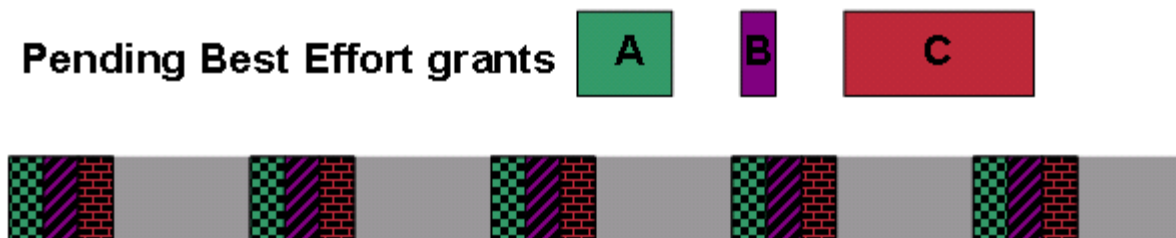

- 2. lépés: aktuális BE kérések kiosztása

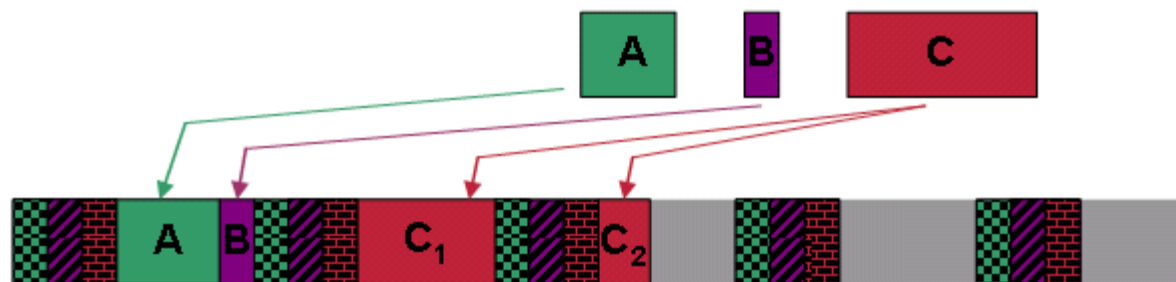

Példa - Scheduling

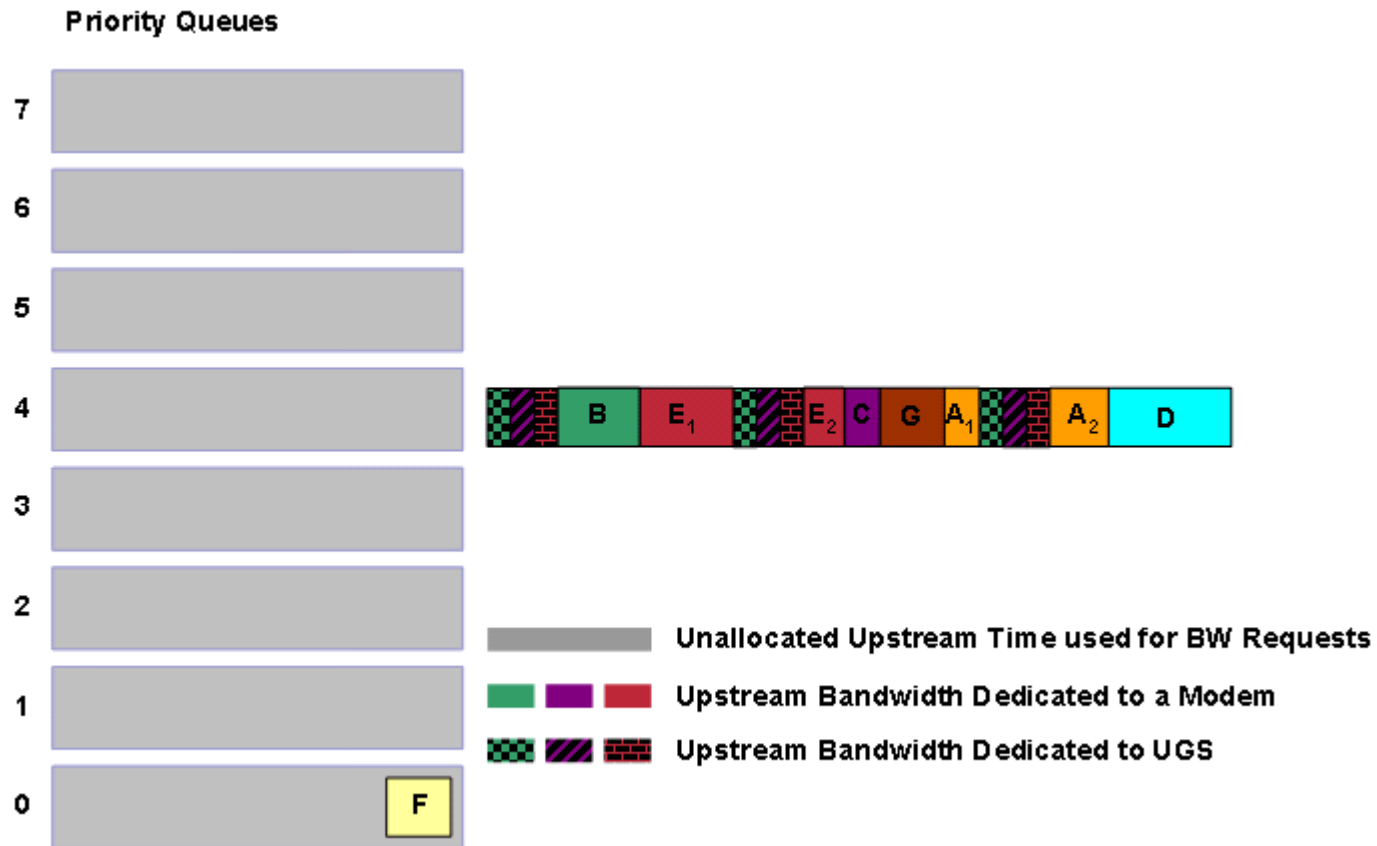



Ethernet

- MAC címek
 - MM:MM:MM:SS:SS:SS
 - MM-MM-MM-SS-SS-SS
- An OUI {Organizationally Unique Identifier}
 - 00:00:0A -- this is owned by Omron
 - 00-0D-4B -- this is owned by Roku, LLC
- <https://www.wireshark.org/tools/oui-lookup.html>
- Broadcast: FF:FF:FF:FF:FF:FF
- Multicast

- Ethernet II vs 802.3 – mikor melyik?
 - Type/length
 - packETH / wireshark
- Tanulás
 - Példa

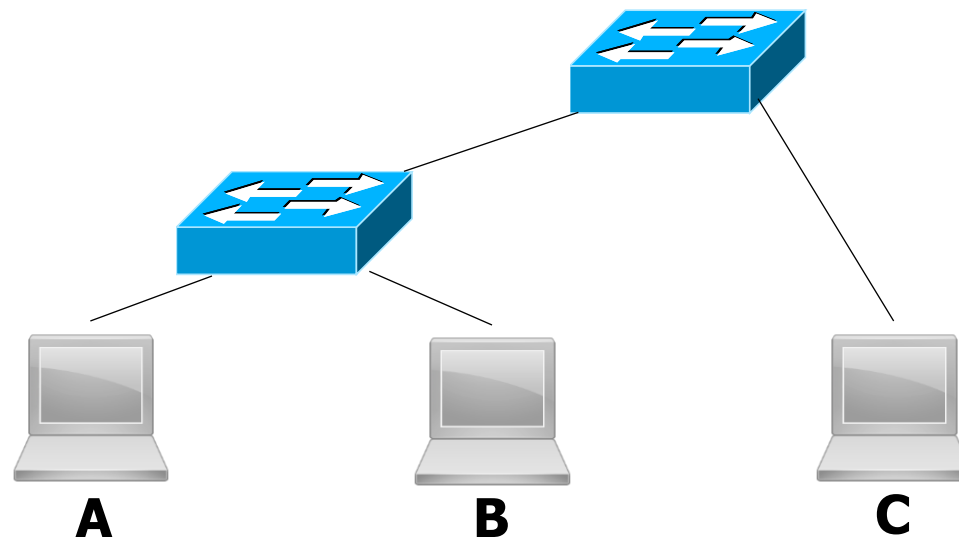

Spanning Tree



- RSTP fa kialakítása
 - BPDU-k
- Paraméterek:
 - Link speed
 - Prioritás
 - ID
- Bridge ID: Prioritás + MAC

Bridge BPDU-k

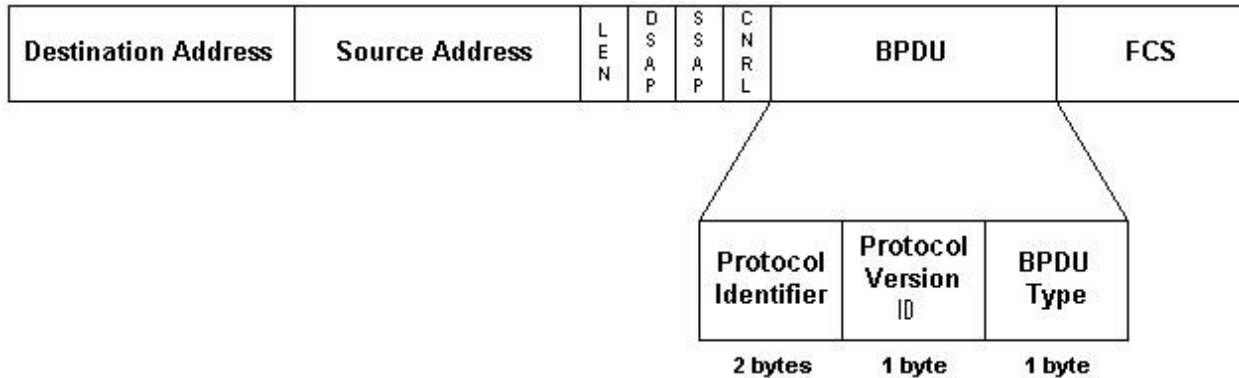
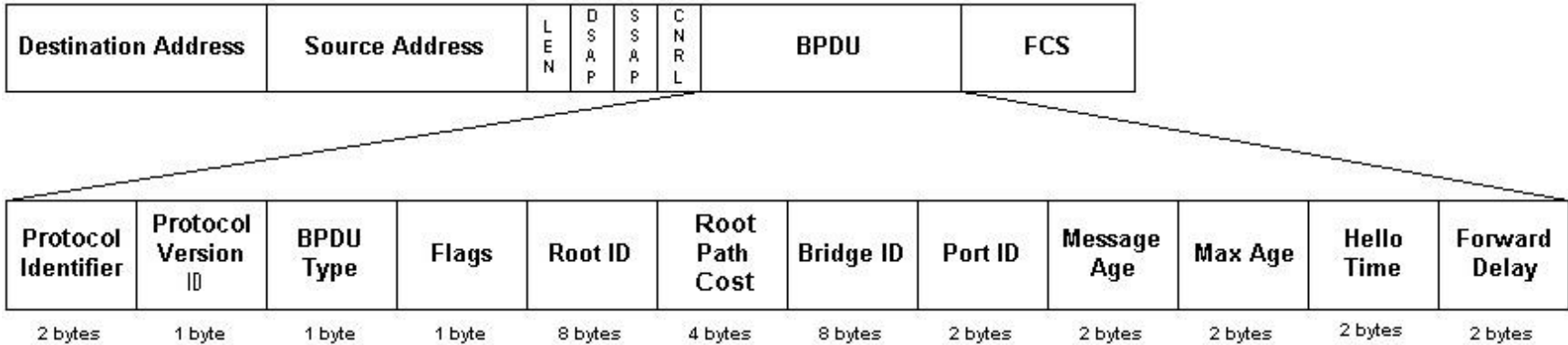

Példa – Fizikai topológia

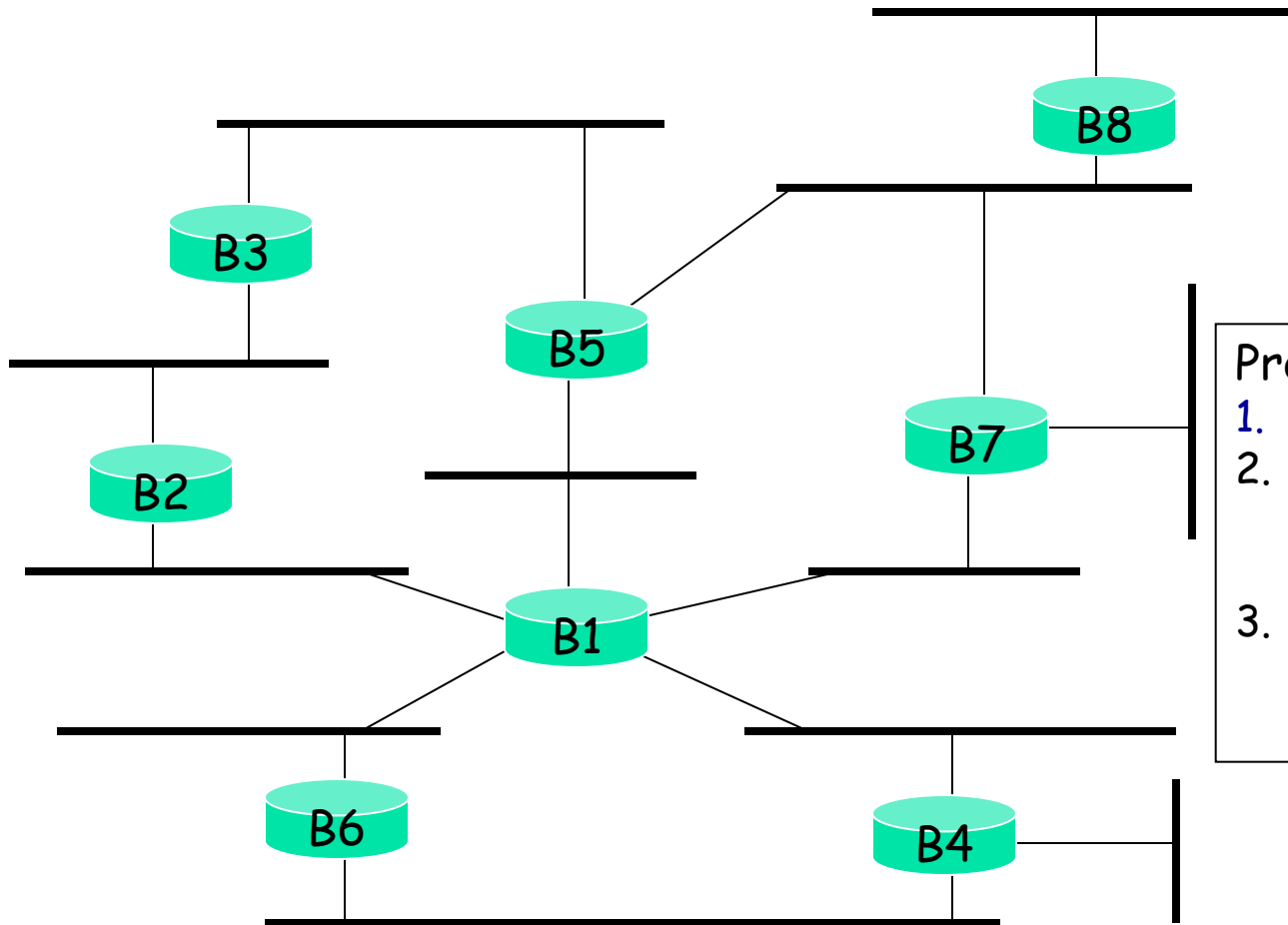

Protocol működés:

1. **Root** kiválasztás
2. minden LAN-ra kiválasztja a **designated** bridge-et, a legközelebbit a root-hoz.
3. Minden bridge a **root** fele a **designated** bridge-en keresztül küld.

Példa – STP Topológia

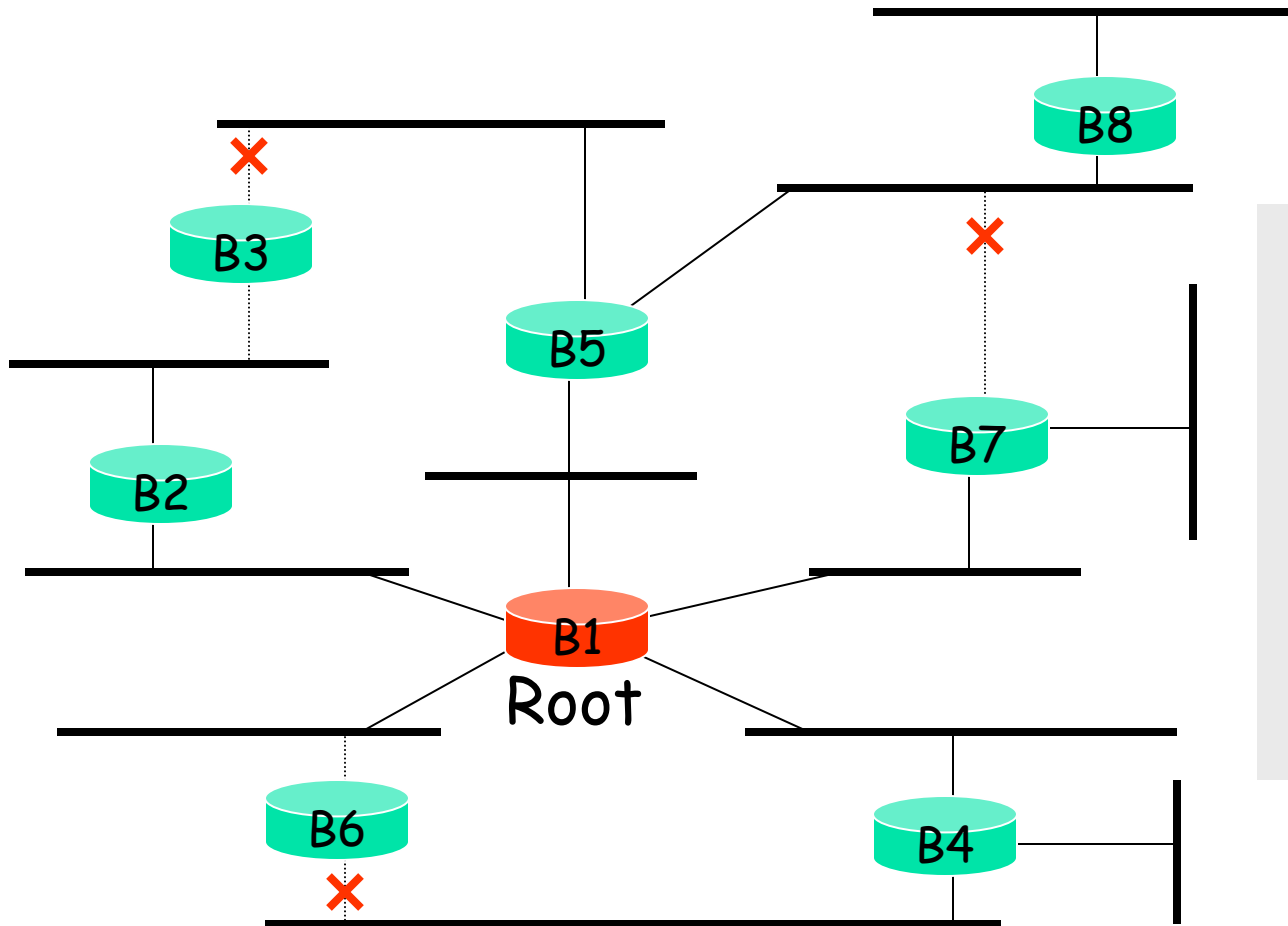

Spanning Tree:

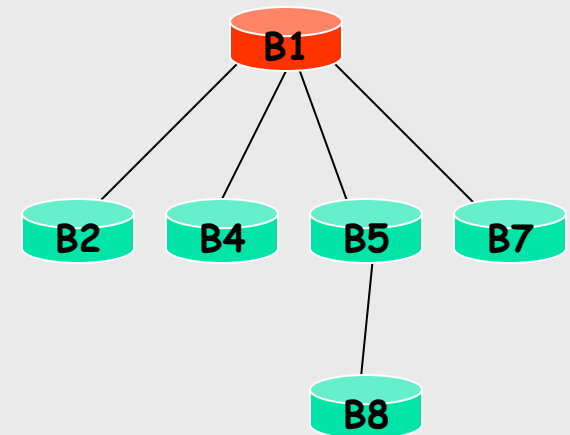

RSTP optimális beállítás



BME-TMIT

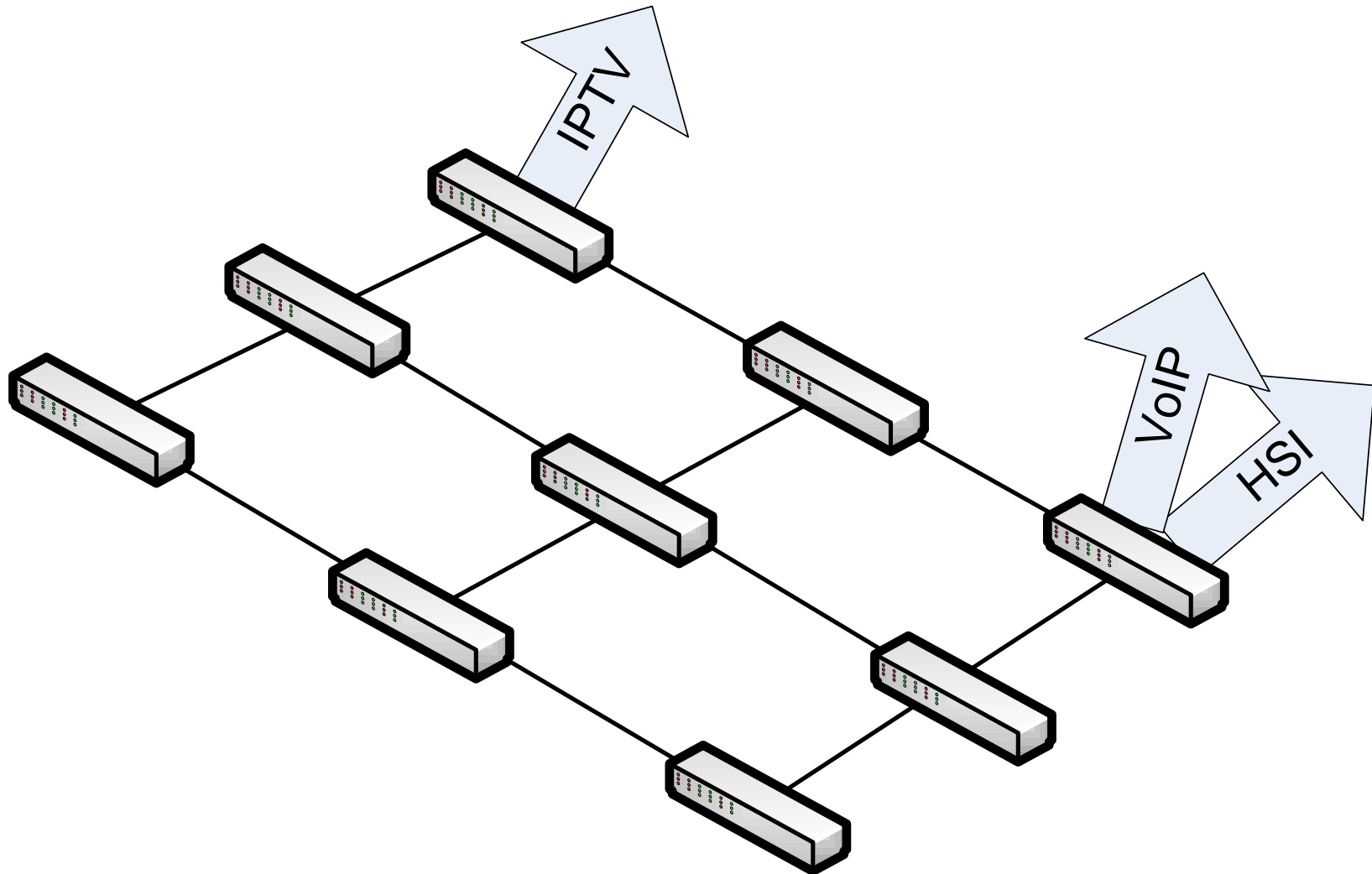

MSTP optimális beállítás



BME-TMIT

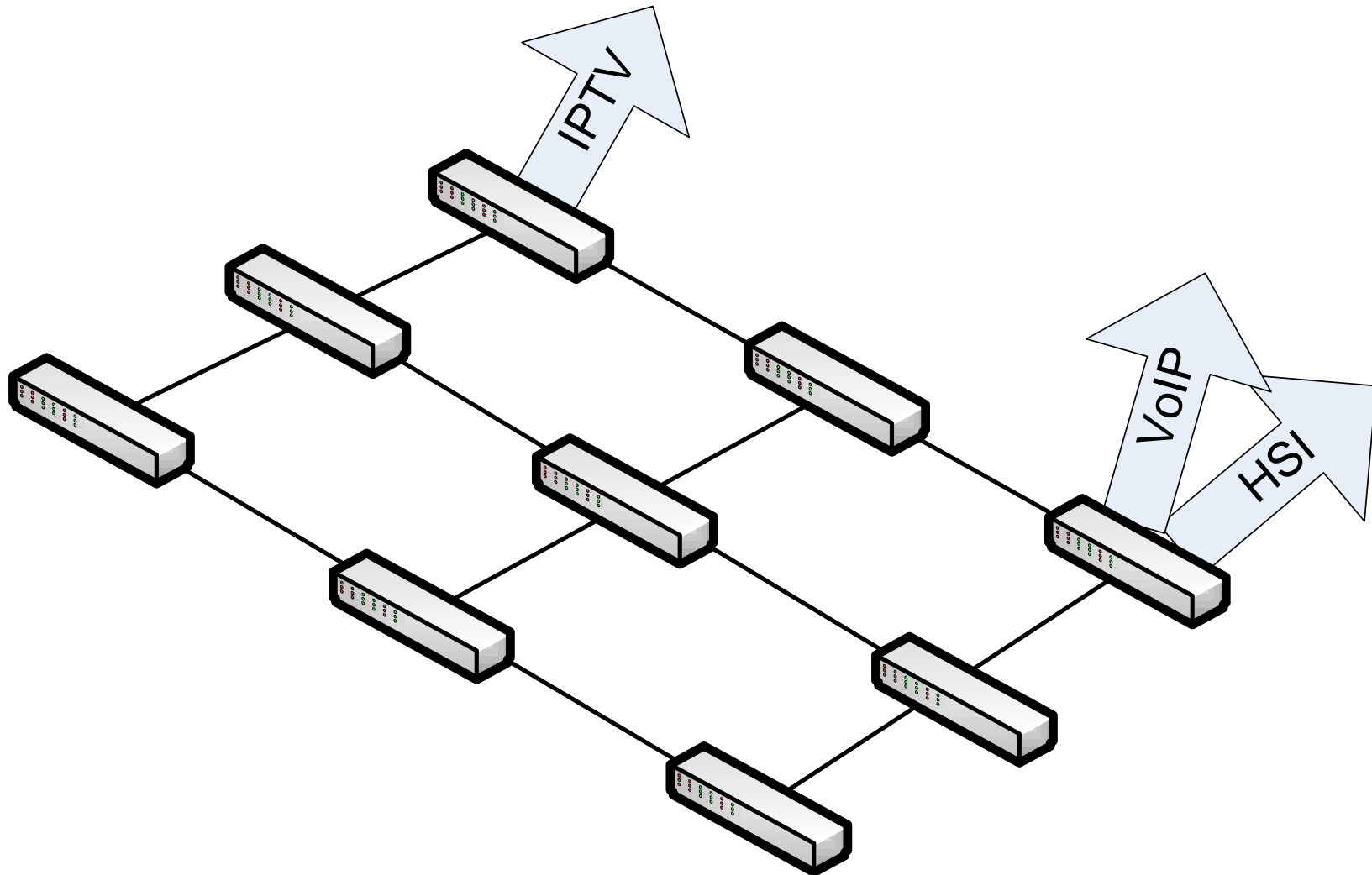

- Layer 2 továbbítás – MAC címek alapján
- Megtanulja a MAC címeket akár a bridge
- Erőssége a store-and-forward működés amely egyidejű továbbítást végezhet különböző portok között
 - Nincs ütközés
 - Nagy sebességű *backplane*
- Nagyszámú interfész
 - Különböző sebességek/médiumok

- A nagyobb teljesítményű kapcsolók egyben bridge-ek is
 - Támogatják az STP protokollt
- Típusok
 - Nem menedzselhető:
 - irodai célokra, HUB-ok összekapcsolására kiváló
 - Nem támogatja az STP protokollt, sem a VLAN-okat (jövő óra)
 - Menedzselhető
 - VLAN és STP támogatás
 - Menedzsment interfész
 - L2/L3

- Hierarchikusan

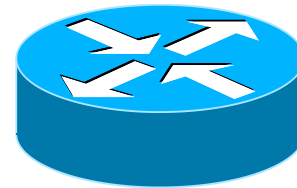

Router

Nagy teljesítményű,
multiservice kapcsoló

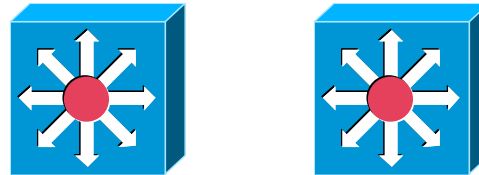

SWITCH, Bridge



HUB



- <https://www.cisco.com/c/en/us/support/docs/broad-band-cable/cable-modem-termination-systems-cmts/69704-upstrm-schdlr-uBRCMTS.html>
- <https://www.youtube.com/watch?v=xIuBmOufbls>
- <https://www.youtube.com/watch?v=5u52wbqBgEY&vl=hu>
- <https://www.youtube.com/watch?v=dIvNkK0PO4w>

Kérdések?



Budapest University of Technology and Economics



Department of
Telecommunications and Media Informatics