

# Communication Networks 2

## Mobile networks 2.

*Gusztáv Adamis*

*BME TMIT*

*2017*



# UMTS



- ❑ UMTS: Universal Mobile Telecommunication System
- ❑ Goal: a really universal 3G system
  - 1G systems: „not compatible even with themselves”
  - 2G: still more, incompatible systems
  - 3G: this could not succeed entirely...
- ❑ ITU: IMT-2000 (International Mobile Telecommunications-2000) standard
  - UMTS (Eu)
  - FOMA: Freedom of Mobile Multimedia Access (Japan)
    - ❑ UMTS compatible
  - CDMA2000: Code Division Multiple Access (US)
- ❑ UMTS also has subversions ☹
- ❑ 3GPP: 3rd Generation Partnership Project standardises
  - ❑ [www.3gpp.org](http://www.3gpp.org)

# UMTS goals

---

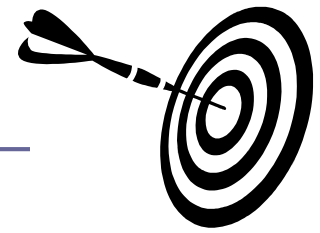

- UMTS goals:
  - better quality of voice (same as in PSTN)
  - better utilisation of spectrum
  - higher data transmission speed
  - backward compatibility with GSM

# UMTS services

---



- Voice transmission:
  - Adaptive MultiRate (AMR) codec (later)
    - 4.7 – 12.2 kbps
- Data transmission, Internet access
  - in cities typically max. 384 kbps, under 120 kmph
  - in rural areas typically max. 144 kbps, 500 kmph
  - in buildings max. 2 Mbps, under 10 kmph
- Multimedia services (next slide)
- Value added services (not only 3G)
  - chat, games, music download, etc.
  - location based services:
    - e.g. where is my girlfriend?, where am I ?!, ATM, pub;
    - emergency call, location based accounting (!)

# UMTS services

- UMTS services:
  - voice transmission
  - data transmission
  - video telephony
  - TV
  - Radio
  - Traffic monitoring cameras
    - Astoria, Fővám tér, Podmaniczky utca, Gellért tér, Kosztolányi Dezső tér, Margit krt., Roosevelt tér, Csepel
  - Hungarorama ((weather) cameras in several cities)
    - Budapest, Esztergom, Visegrád, Siófok, Győr, Sárvár, Veszprém, Lillafüred, Balatonfüred
  - Downloading music, videos - streaming
  - Etc, etc.
  
- But still no „killer application”!!! ☹



# Radio interface



- Frequencies:
  - 1885-2025 MHz uplink
  - 2110-2200 MHz downlink
    - reserved for satellite: 1980-2010 MHz up, 2170-2200 MHz down
- Medium access:
  - *CDMA*, Code Division Multiple Access
  - Same frequency, same time, different code
    - like: multilanguage airport waiting hall
  - Every signal is spread in the whole spectrum, but with small power
  - Goal: better utilisation of the spectrum

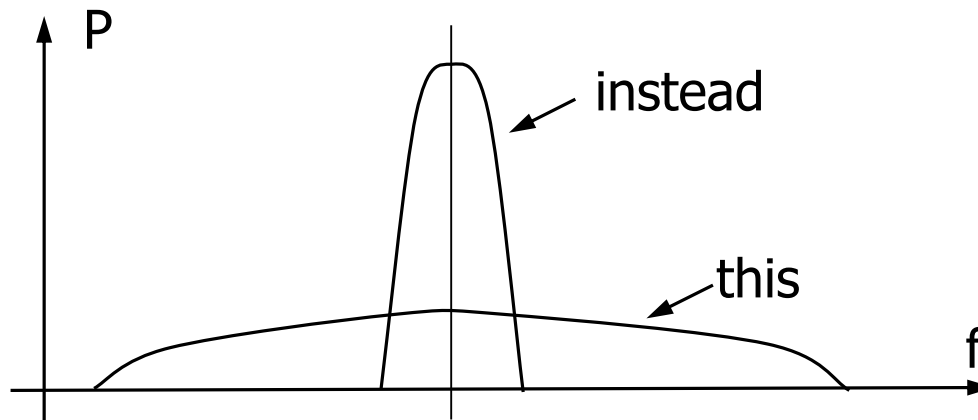

# FDMA

## Frequency Division Multiple Access

- Orthogonal in frequency within cell
- Narrow bandwidth per carrier
- Continuous transmission and reception
- No synchronization in time

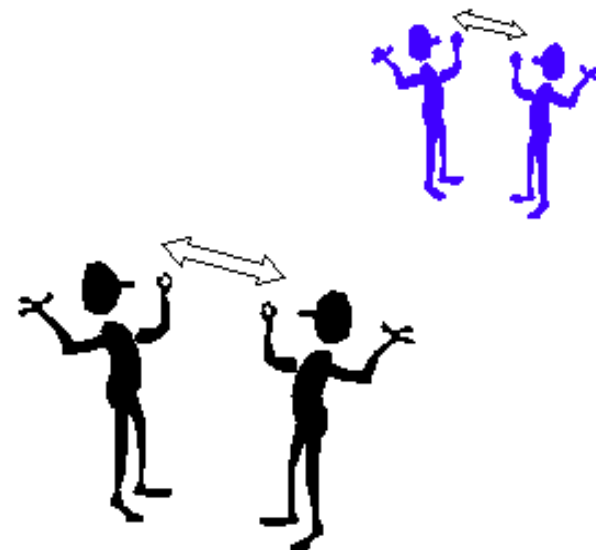
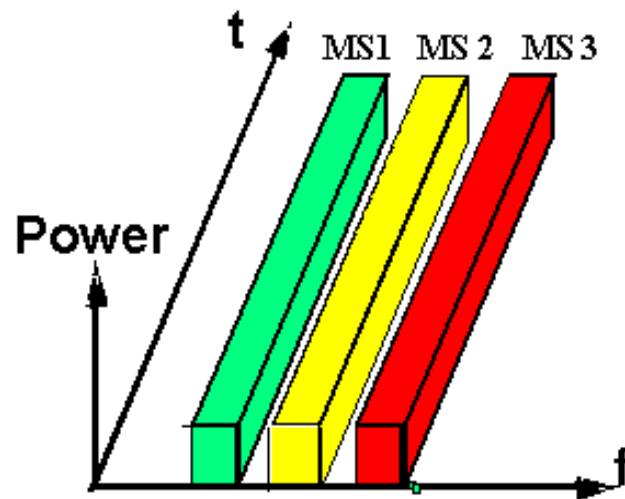

# TDMA

## Time Division Multiple Access

- Orthogonal in time within cell
- Increased bandwidth per carrier
- Discontinuous transmission and reception
- Synchronization in time

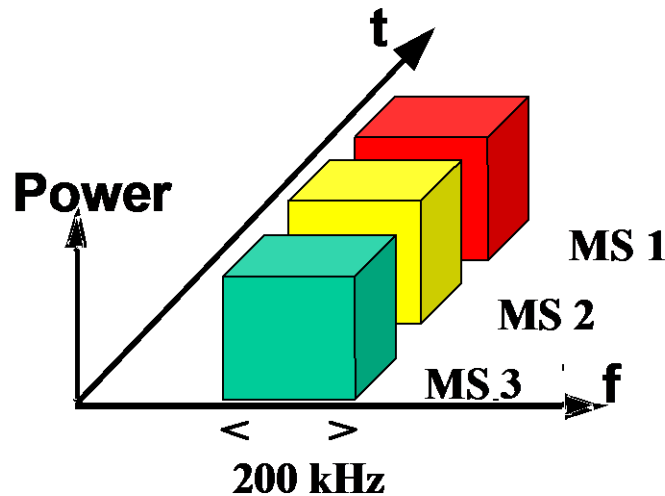



# CDMA

## Code Division Multiple Access

- Separate users through different codes
- Large bandwidth
- Continuous transmission and reception

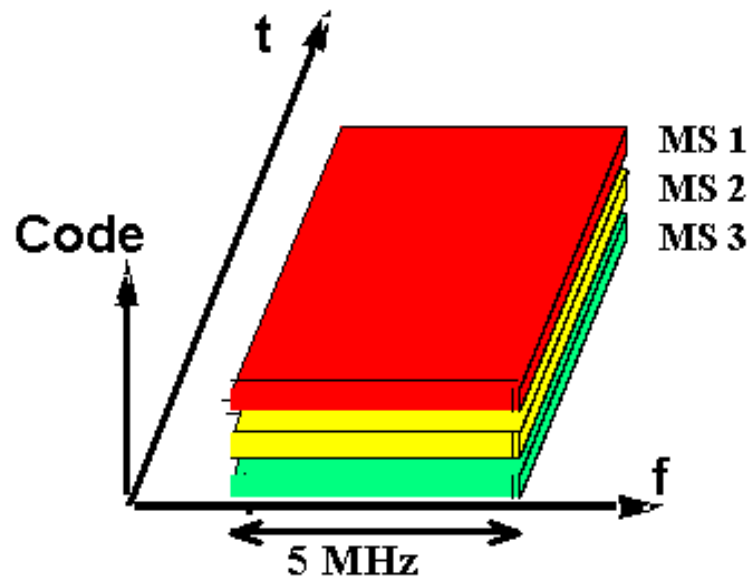

# CDMA International Cocktail Party



**What can YOU hear/understand...**

**...if you speak only Japanese?**

**...if you speak only English?**

**...if you speak only Italian?**

**...if you speak only Japanese, but the Japanese-speaking man is at the other corner of the hall?**

**... if you speak only Japanese, but the Spanish cries loudly?**

**Japanese**

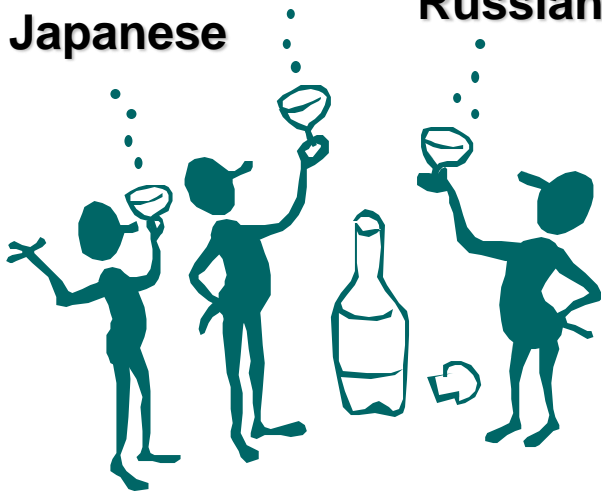

**Russian**

**Spanish**



**Italian**

# Code sharing

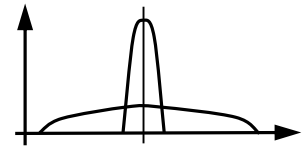

- The digital signal is multiplied with a so-called spreading code, and the result is to be transmitted
  - multiplication: NOT(XOR(bit1,bit2))
  - transmitted signal is added to the other signals transmitted by other mobiles
- The bitrate of the spreading code (chiprate) much greater (appr. 100x) than that of the „useful” signal
- The spreading codes are orthogonal, that is the average of multiplication of any two spreading codes is 0

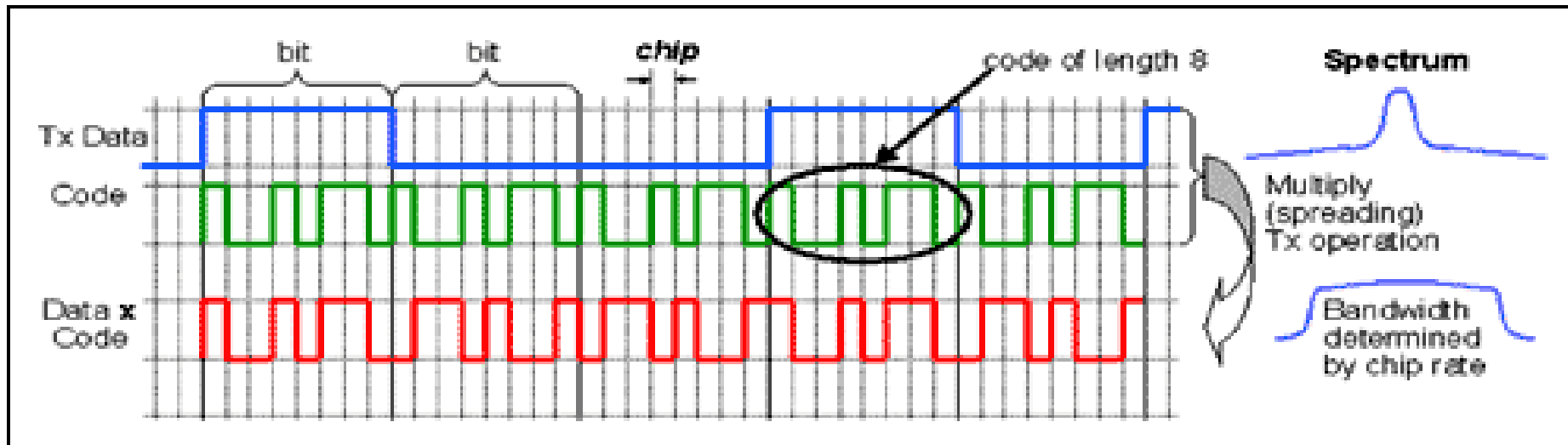

# Code sharing

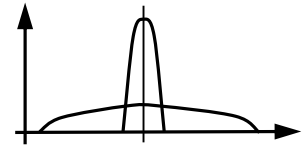

- A bit more detailed:
- Encoding
  - STEP 1. Let us represent the bits of the spreading code and the bits of the data to be encoded in the following way:
    - $1 \rightarrow 1$
    - $0 \rightarrow -1$
    - Recognise: this case NOT(XOR(a,b)) is actually  $a*b$ 
      - $1*1=1, 1*-1=-1, -1*1=-1, -1*-1=1$
  - STEP 2. Let us multiply the spreading code with the data to be transmitted
    - multiply every bit of the spreading code with *one* bit of the data (this way the signal speed increases remarkable)
  - STEP 3. Let us transmit the multiplied signal on the common frequency
    - In our model we simply add all the signals
- Decoding
  - STEP 1. Let us multiply the received signal (sum of STEP 3 of encoding) with the bits of the spreading code of the transmitter. (As many times, as many bits we want to receive.)
  - STEP 2. Let us average the values calculated this way for (data) bit durations
  - STEP 3. If average 1: sent bit 1. If average -1: sent bit 0
  - STEP 4. Let us do this for every receiver

# Code sharing

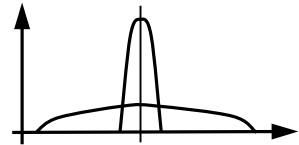

□ Example for encoding:

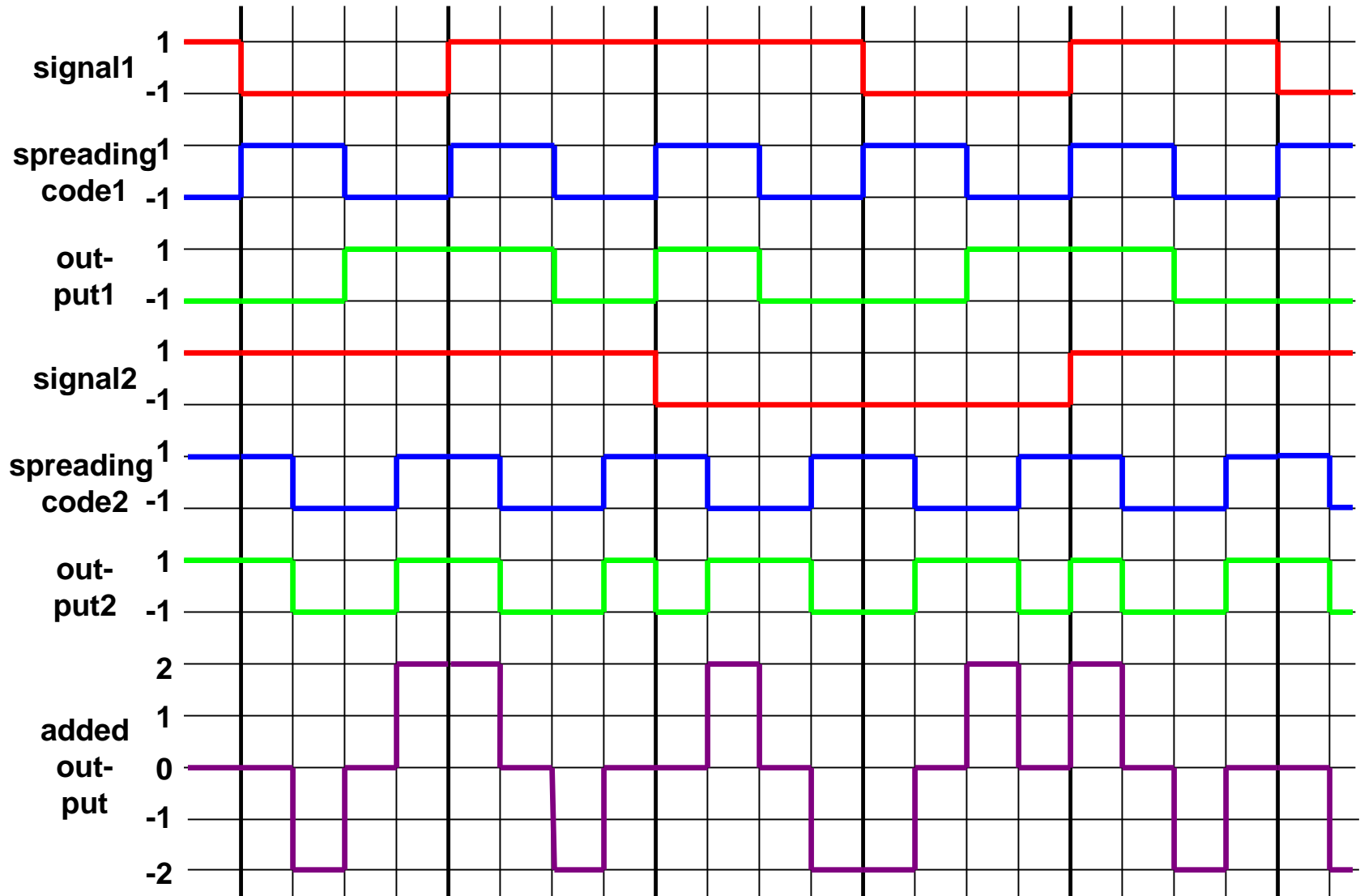

# Code sharing

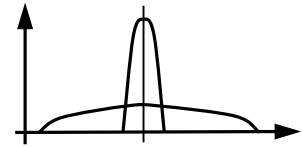

- Example of decoding:

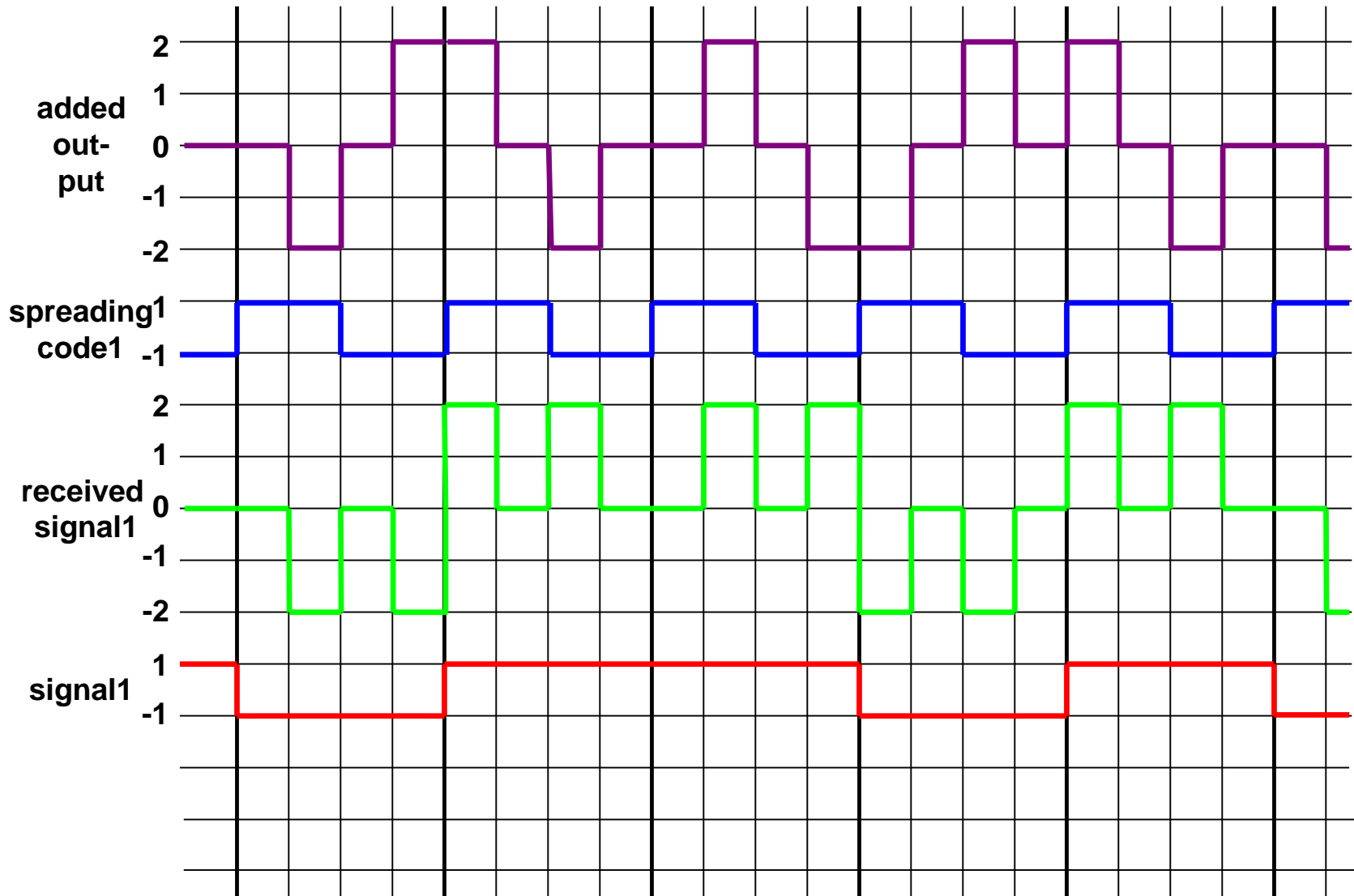

# Code sharing

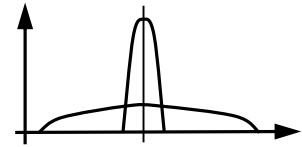

## □ Let us see a numerical example!

- Let us transmit the signals  $(1, 0)$  and  $(1, 1)$  with using the  $(1, 1, 0, 0)$ , and  $(1, 0, 0, 1)$  spreading codes

## □ Encoding:

- STEP 1. Data signals are:
  - A:  $(1, -1)$
  - B:  $(1, 1)$
- STEP 1. The two spreading codes are:
  - A:  $(1, 1, -1, -1)$
  - B:  $(1, -1, -1, 1)$
- STEP 2. Signals to be transmitted:
  - A:  $1, 1, -1, -1, -1, -1, 1, 1$
  - B:  $1, -1, -1, 1, 1, -1, -1, 1$
- STEP 3. Sum of them:
  - $2, 0, -2, 0, 0, -2, 0, 2$

## □ Decoding

- STEP 1. The multiplication:
  - A:  $2, 0, 2, 0, 0, -2, 0, -2$
  - B:  $2, 0, 2, 0, 0, 2, 0, 2$
- STEP 2. Averages:
  - A:  $1, -1$
  - B:  $1, 1$
- STEP 3. Received signals:
  - A:  $1, 0$
  - B:  $1, 1$

- Comment: we could do this, because the spreading codes are really orthogonal, that is the average of the multiplication of the two spreading codes is really 0:

- The multiplication of the two spreading codes:  $1, -1, 1, -1$
- The average: 0

# Spreading code generation

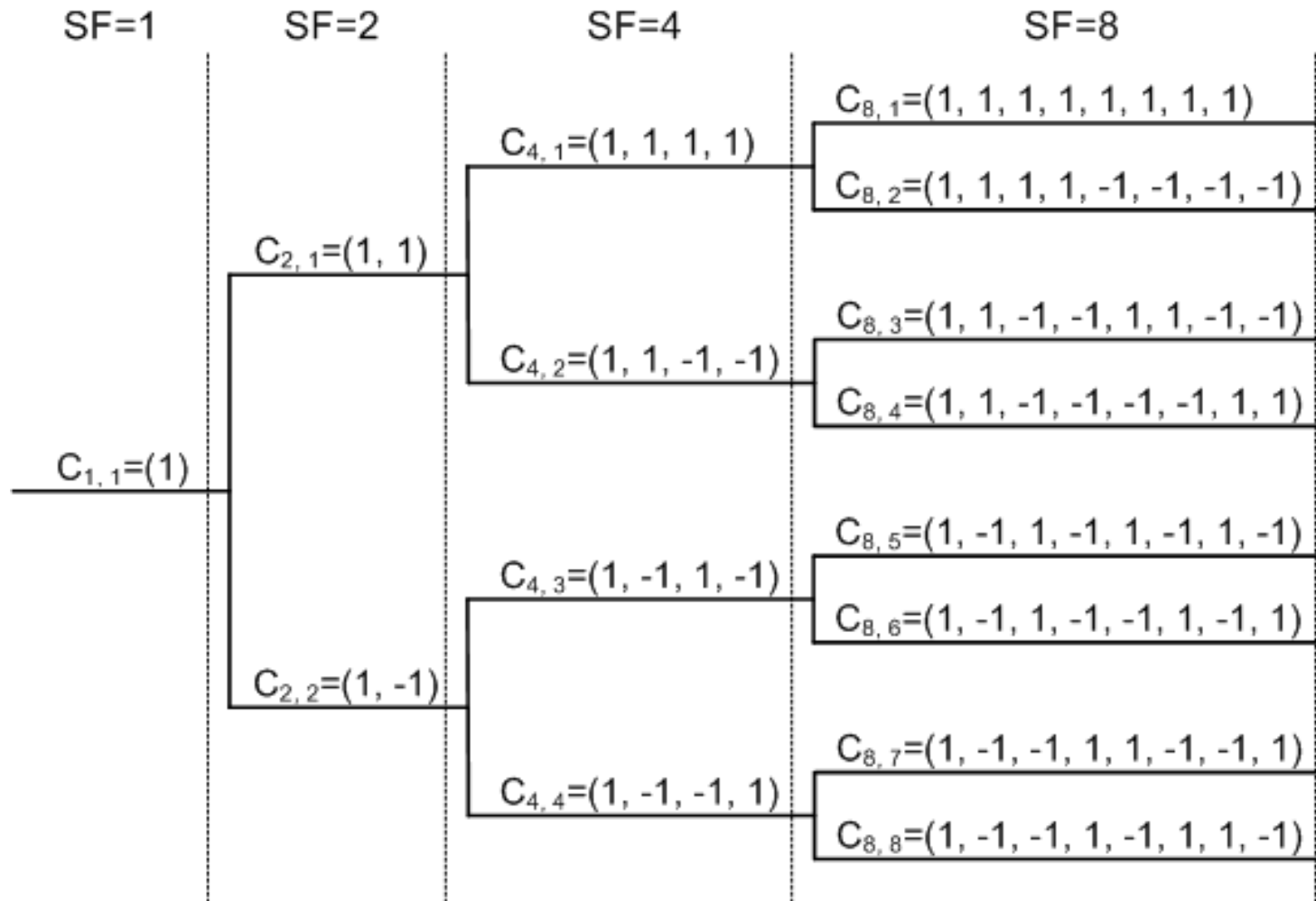



# GSM/GPRS architecture („2,5G”)

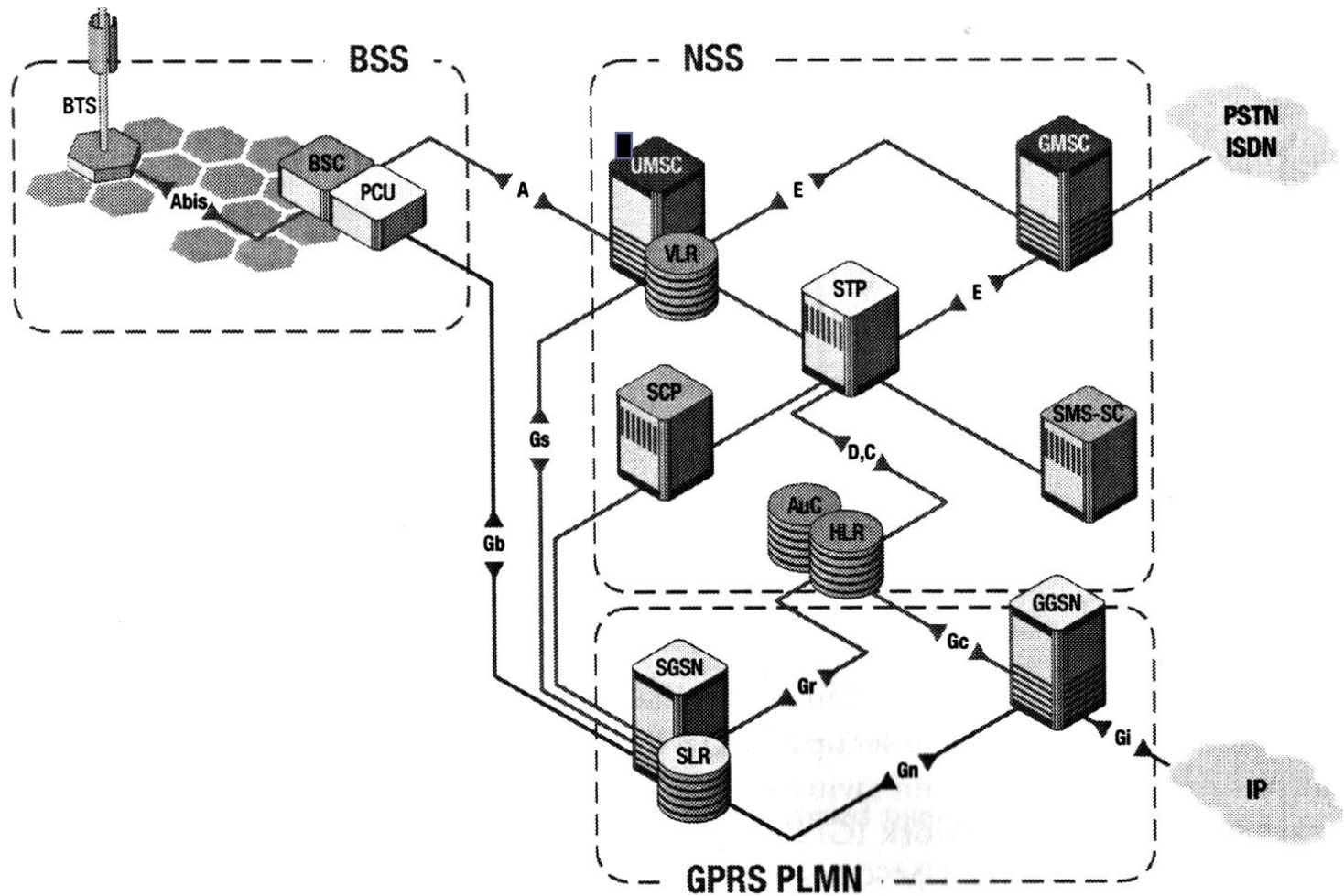

# UMTS R'99 architecture

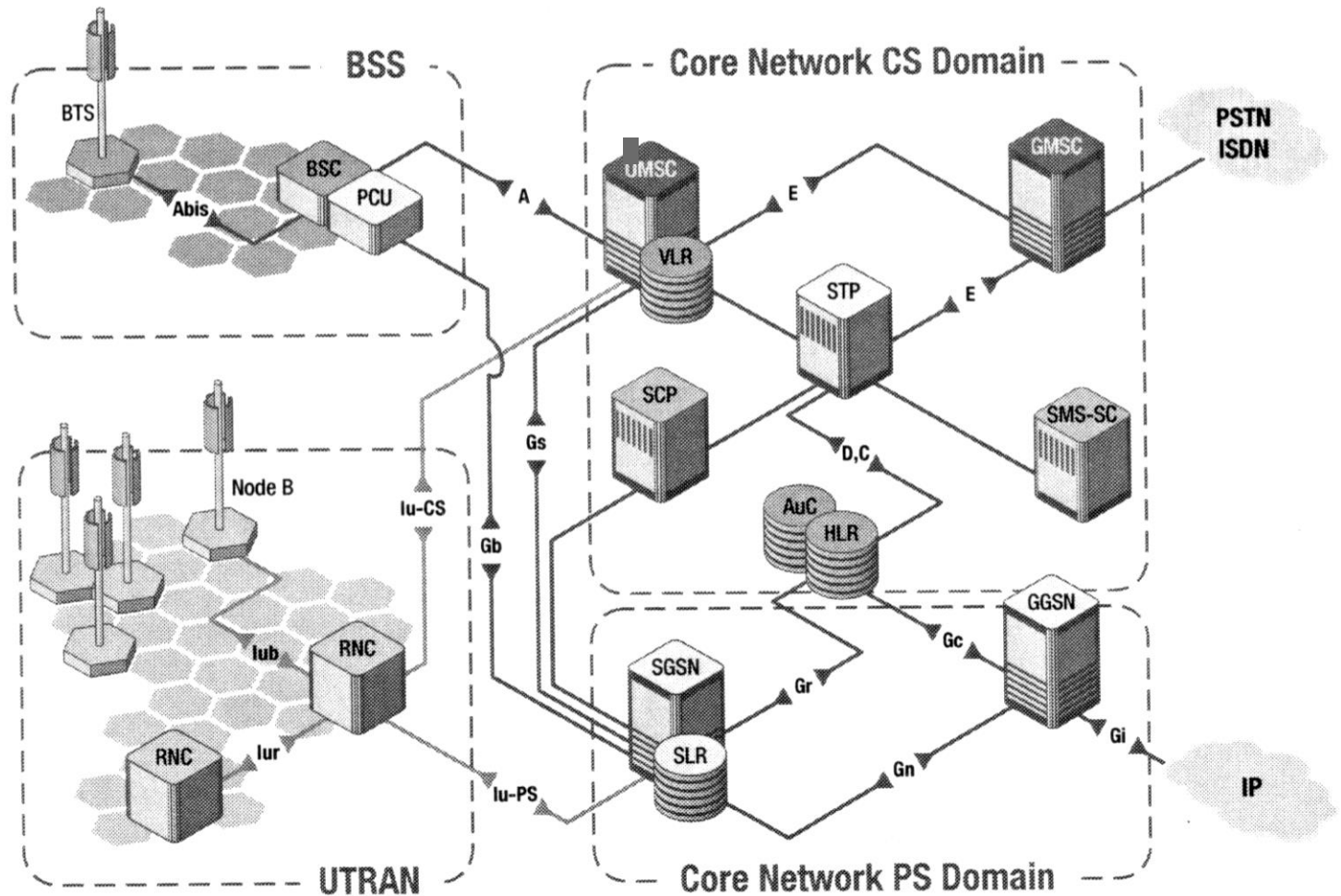

UTRAN: Universal/UMTS Terrestrial Radio Access Network

# The UMTS network

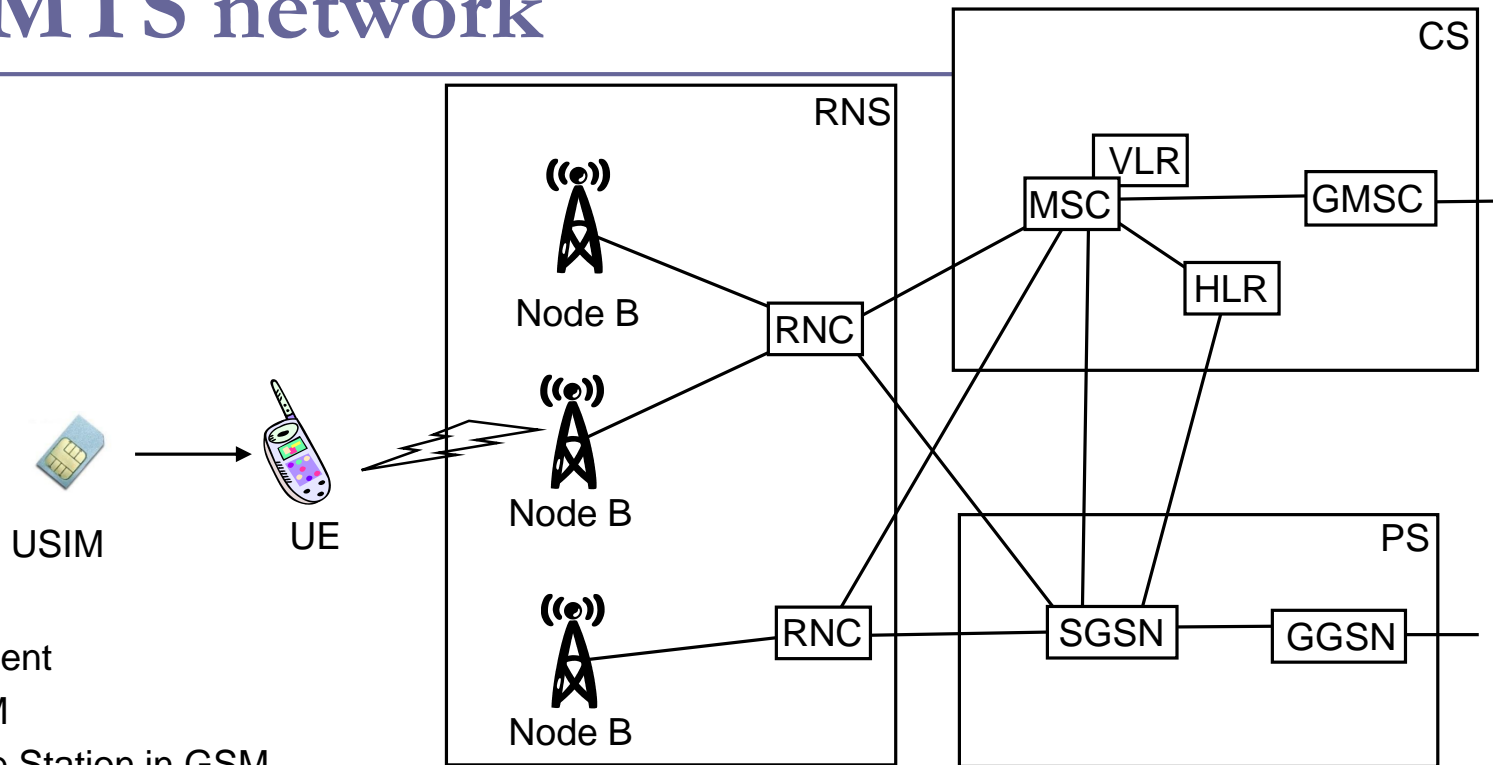

UE: User Equipment

USIM: UMTS SIM

Node B: like Base Station in GSM

RNC: Radio Network Controller, (like BSC in GSM)

RNS: Radio Network Subsystem

MSC, HLR, VLR: same as in GSM

GMSC: Gateway MSC: MSC and gateway to other network(s) (e.g. ISDN)

CS: Circuit Switched subsystem

SGSN: Serving GPRS Support Node

GGSN: Gateway GPRS Support Node: packet switch and gateway to other network(s) (e.g. Internet)

PS: Packet Switched subsystem

UMTS Release 99: Core Network ~ GSM+GPRS, Radio IF different

# Duplexity management in UMTS

---



- Task to solve: Separate the up- and downlink data
- The possible solutions:
  - in time
  - in frequency
- Both used in UMTS (but not at the same time)
  - FDD: Frequency Division Duplexing
    - higher frequency in downlink direction (greater attenuation → greater power needed)
  - TDD: Time Division Duplexing
    - advantage: the ratio of the up- and download can be dynamically changed according to the current needs
    - (ping-pong method)

# Handover – circuit switched

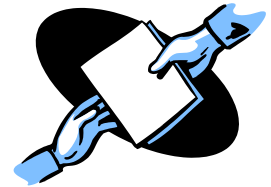

## □ GSM: hard handover

- MS communicates with either base station then, in the next time slot with the other one
- the handover is as fast as it can be
- cell change with hysteresis: to reduce the number of handovers in the case when the MS moves at the boundaries of the cells

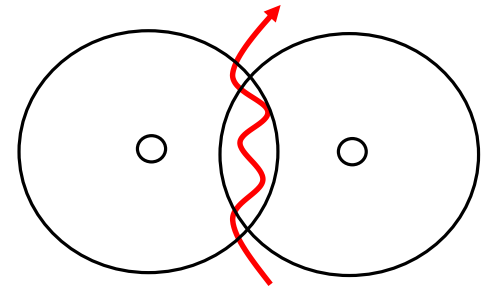

# UMTS soft handover

---

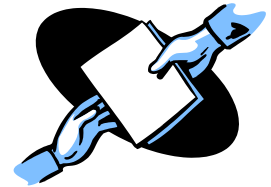

- UMTS: soft handover
  - UE is in contact with more (max. 3) base stations
  - downlink data (the same) is transmitted by all of them – so the UE receives it from several sources
    - so if something is lost from a given base station it can be replaced from the others
  - uplink data (the same) is received by every base station
    - the network assembles the pieces of data received by the different base stations – so if data is lost in a cell it may be corrected by those received in the other cells
  - this connection to several base stations can last a relatively long time
- The redundancy is important, because we are at the edge of the cell, where the receive is the worst
  - but redundant transmission requires a bit of waste of bandwidth
- The code sharing makes it possible:
  - same frequencies in neighbouring cells

# UMTS power control



- ❑ The orthogonality of the applied spreading codes is not perfect
- ❑ In a base station when receiving the signal of a UE, the signals of the other UEs appear to be noise
  - (no such a problem in downward direction, since only the Node B transmits)
- ❑ So the signal of every UE must arrive to the Node B with the same power
  - otherwise the strongest suppresses all the others
- ❑ Solution: Node B orders the UEs to reduce/increase the transmission power
- ❑ 1500 times/sec (!)
  - Else e.g. a UE comes out from the shadow of a building (till that time transmitting with great power) will destroy the communication of the whole cell
- ❑ While in GSM:
  - to reduce the usage of batteries, to reduce the physiological risks
  - to avoid interference with far cells using the same frequency
  - 2 times/sec (!)

# Power control at soft handover

---

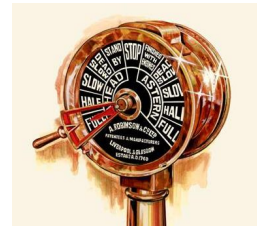

- UE in soft handover may receive different power controlling commands from the different Node Bs:
  - increase/keep/decrease the power
- The rule:
  - If anybody orders to decrease: UE decreases.
  - Otherwise if anybody orders to keep: UE keeps.
  - Otherwise UE increases.
- The idea: To transmit with the minimal power, in order not to destroy the communication in none of the cells. But if UE keeps the rules above it follows that the power will be enough at least in one of the cells.



# UMTS cell breathing

---



- More users in a cell
- → bigger „background noise”
- → smaller is the effective size of the cell
  - the far UE should transmit with larger than the maximal power
- ⇒ the size of the cell depends on the traffic
  - cell is „breathing”
- makes the design of the cell structure more complicated



## HSPA (High-Speed Packet Access)

- Improvement of UMTS to higher data transmission speeds
- Common name of 2 protocols:
  - HSDPA (High Speed Downlink Packet Access)
    - up to 14.4 Mbps
    - in Hungary today: 0.6 – 1.3 Mbps
    - <http://index.hu/tech/mobil/hsdpa1005/>
  - HSUPA (High Speed Uplink Packet Access)
    - up to 5.6 Mbps
    - near future
- Higher speed access methods (50-100 Mbps...) are yet under development

# UMTS R'99 architecture

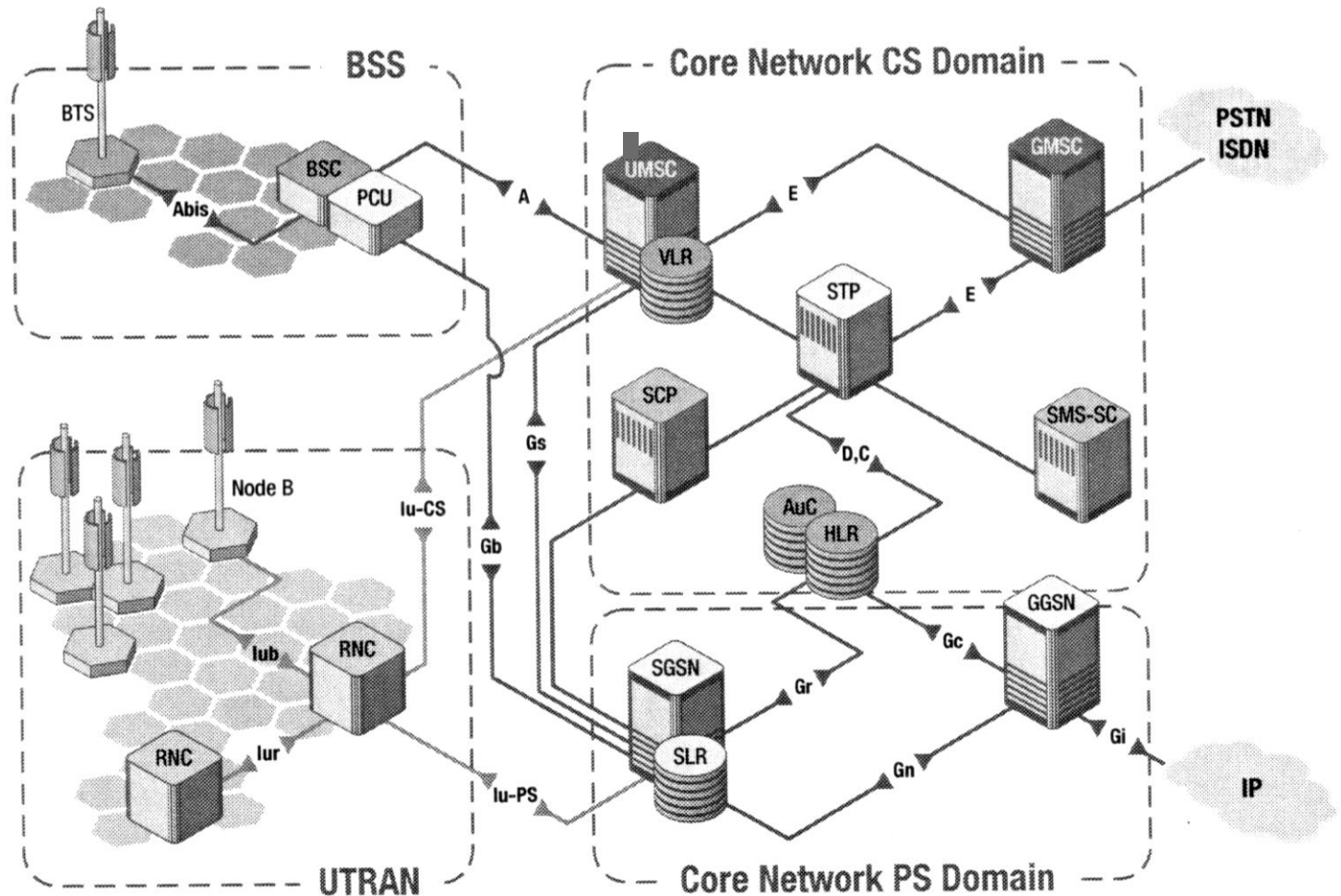

UTRAN: Universal/UMTS Terrestrial Radio Access Network

# UMTS R4 architecture

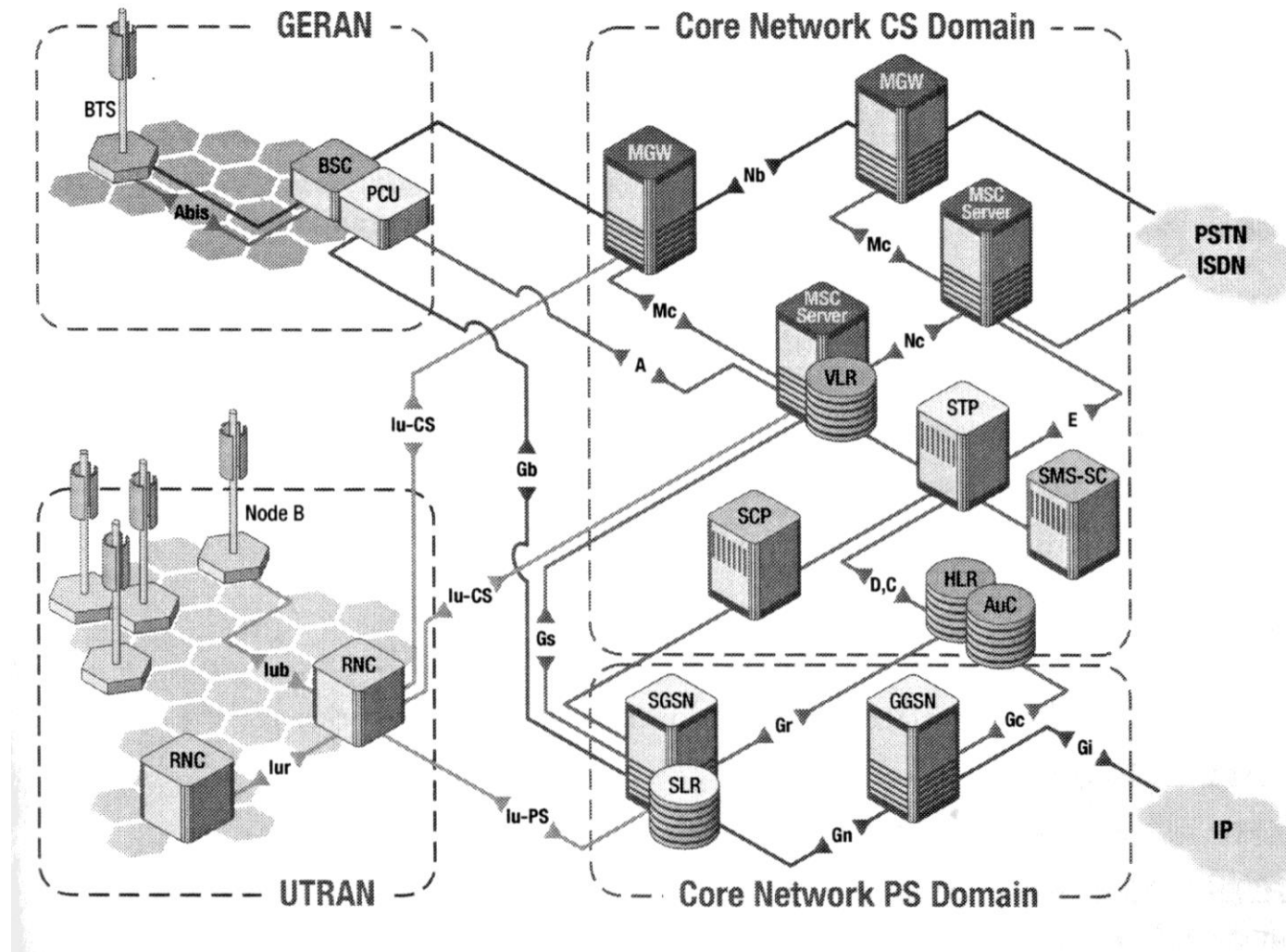

GERAN: GSM EDGE Radio Access Network

# Separation of functions of switches

---

- (G)MSC Server [ (G)MSS ] is responsible for:
  - Signaling (call control)
  - a mobility management (together with VLR)
- MGW – Media Gateway is responsible for :
  - Transmission of user traffic (voice, data) within core network
  - Protocol conversion towards
    - Radio access network (UTRAN, GERAN)
    - PSTN/ISDN
    - Previous mobile networks (Before Rel 4)
  - Goal: any protocol should be used between MGWs
  - IP or ATM
    - az MGW is actually an ATM switch or an IP router
    - if IP:

# UMTS Release 4 – Control/User Plane

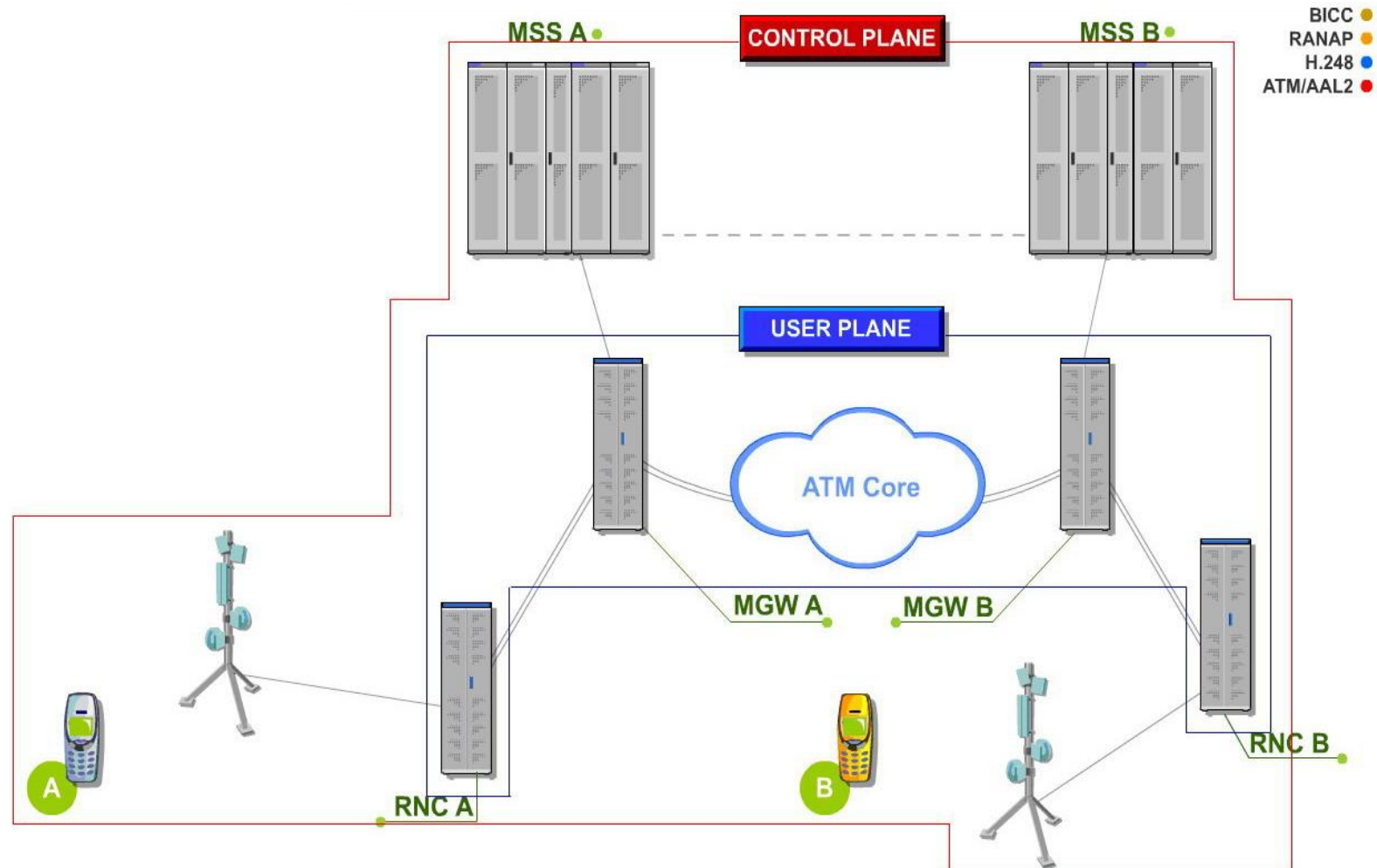

# Future: All IP UMTS core network

---

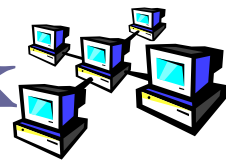

- Current UMTS core: ATM
- Future (?) : All IP core network:
  - Advantages of IP core:
    - More services
    - More flexible
    - Cheaper
    - MGW (VoIP!!) and SGSN can be integrated
  - Disadvantages of IP core:
    - An other conversion is needed
    - Reliability is not yet obvious

# Next Generation Networks

---

- Next Generation Networks, NGN
- Basic idea: Build a *common* core network for different *services*:
  - voice transmission (telephone)
  - videotelephony and other multimedia data transfer
  - television
  - Internet
  - Virtual Private Network, VPN
  - instant messaging (chat)
  - distributed games
  - other, existing and not yet existing services



# NGN architecture

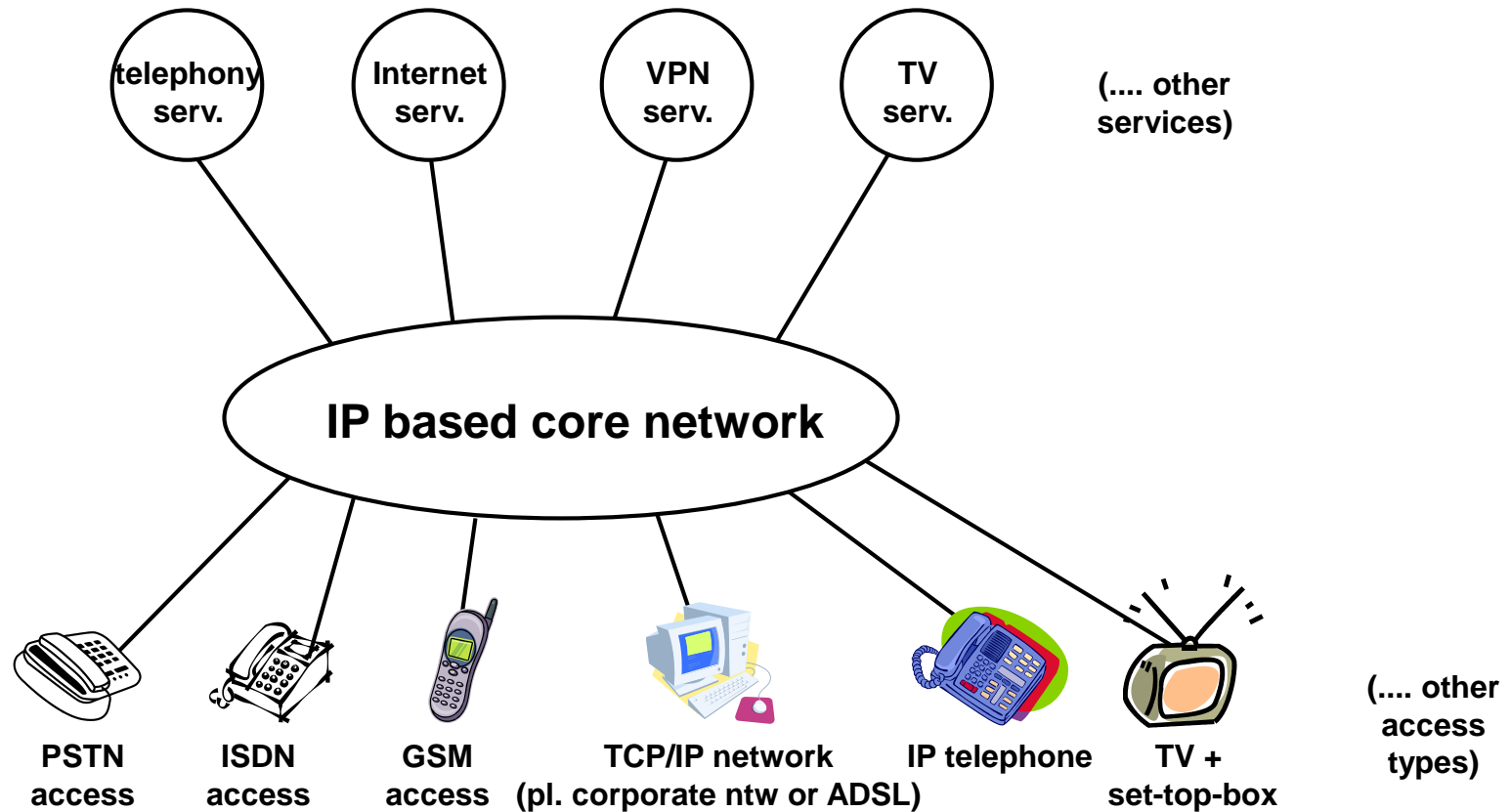

- NGN is a concept, and not a concrete technology

# Next Generation Networks

---

- These services can be reached from:
  - different terminals
  - different access networks
- But the service is the same
- And for each service
  - same core network (transport network)
  - full IP based („all-IP network”)
- E.g. a telephone call may end on the called party's:
  - fixed telephone
  - mobile
  - PC
  - PDA through WLAN
  - depending how the called party has set it
  - independently what the calling party dialled