

Telecommunication Networks and Services

Signalling

Gusztáv Adamis
BME TMIT
2015



Content



- 1. Introduction
 - Voice digitalisation
- 2. Access to IP networks through telecommunication and cableTV networks
- 3. Switching
- 4. Mobile networks
- 5. **Signalling** ←

Signalling

□ 6. Signalling

■ **6.1 Overview**

■ 6.2 Subscriber signalling

■ 6.3 Inter-switch signalling (SS7)

■ 6.4 GSM signalling

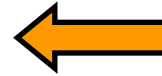

Overview of signalling systems



- Why do we need signalling systems?
 - Communication of terminals and network nodes
- Signalling systems may be (according their place in the network)
 - subscriber signalling systems: between a terminal and a switch (User-network interface, UNI)
 - network signalling systems: between switches and/or other network elements (Network-to-Network Interface, NNI)
- Encoding of signals may be
 - analogue (e.g. voice frequency signal – e.g. DTMF)
 - digital message (similar to the protocols of computer networks)
- Connection with voice path
 - Channel Associated Signalling
 - Common Channel Signalling, CCS (independent from voice path)

Signalling

- 6. Signalling
 - 6.1 Overview
 - 6.2 Subscriber signalling ←
 - 6.3 Inter-switch signalling (SS7)
 - 6.4 GSM signalling



Analogue terminal



- Classification on frequency used:
 - DC: closing of local loop: ringing tone request
 - almost DC: periodical cutting of local loop: dialled number transmission („PULSE mode”, 66ms+33ms)
 - under voice band: ringing 25 Hz (15-68 Hz, USA 20 Hz, Eu. typically 25 Hz, 40-150V (!) AC)
 - in voice band (*in-band signalling*)
 - subscriber → switch: DTMF (Dual Tone Multi Frequency)
 - sum of two sinusoid signals

F (Hz)	1209	1336	1477	1633
697	1	2	3	A
770	4	5	6	B
852	7	8	9	C
941	*	0	#	D

- switch → subscriber: dial tone, ringing tone, engage signal, etc. (mainly for humans, not for machines)

Analogue terminal

□ Classification on frequency used (cont.):

■ in voice band:

□ Calling number presentation during ringing

- in the gaps between ringing transfer of digits by FSK (Frequency Shift Keying) modulation

■ Modulating signal:



■ Modulated signal:



□ SMS in fixed network:

- FSK, the terminal acts as a simple modem (digital signal even in analogue equipments)

■ over voice band: tariff pulses (12-16 kHz)

□ payphones

Digital terminal (ISDN)



- DSS1: Digital Subscriber Signalling System No. 1.

3rd layer
LAPD
physical layer

- 1st (physical) layer: ISDN D channel
- 2nd LAPD: Link Access Procedure on D channel
 - framing
 - error-free transmission between a switch and a terminal: connection-oriented
 - addressing: Terminal Endpoint Identifier (TEI)
 - fixed or automatical (controlled by switch) assignment

LAPD

- 3 different LAPD frame types:
 - U (Unnumbered): 2nd layer (LAPD) connection control (establishment, release)
 - I (Information): 3rd layer (call control) message transfer
 - S (Supervisory): control the sending of I frames

LAPD U frames

Acronim	Name	Meaning
SABME	Set Asynchronous Balanced Mode Extended	LAPD connection establishment request
UA	Unnumbered Acknowledgement	ack. for SABME and DISC
DISC	Disconnect	LAPD disconnection request
DM	Disconnected Mode	Indication of inability of LAPD connection establishment
UI	Unnumbered Information	Unnumbered info transfer (Aut. TEI management, network → terminal Setup)

DSS1 3rd layer

- 3rd layer: sometimes we call as DSS1 for short
 - call establishment/release with signalling messages
 - an example on next slide
 - with LAPD messages!

DSS1 example: call establishment

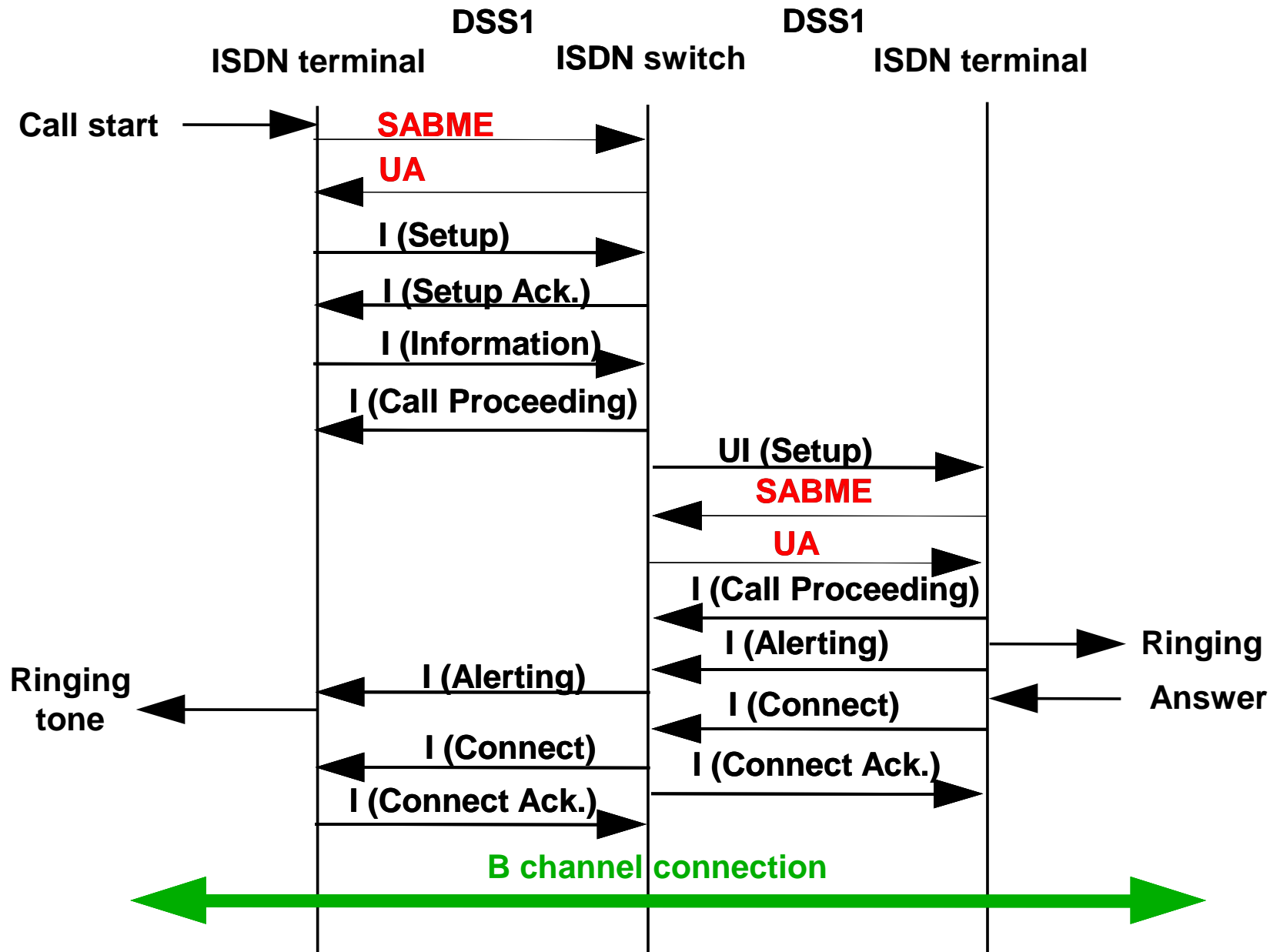

DSS1 example: call release

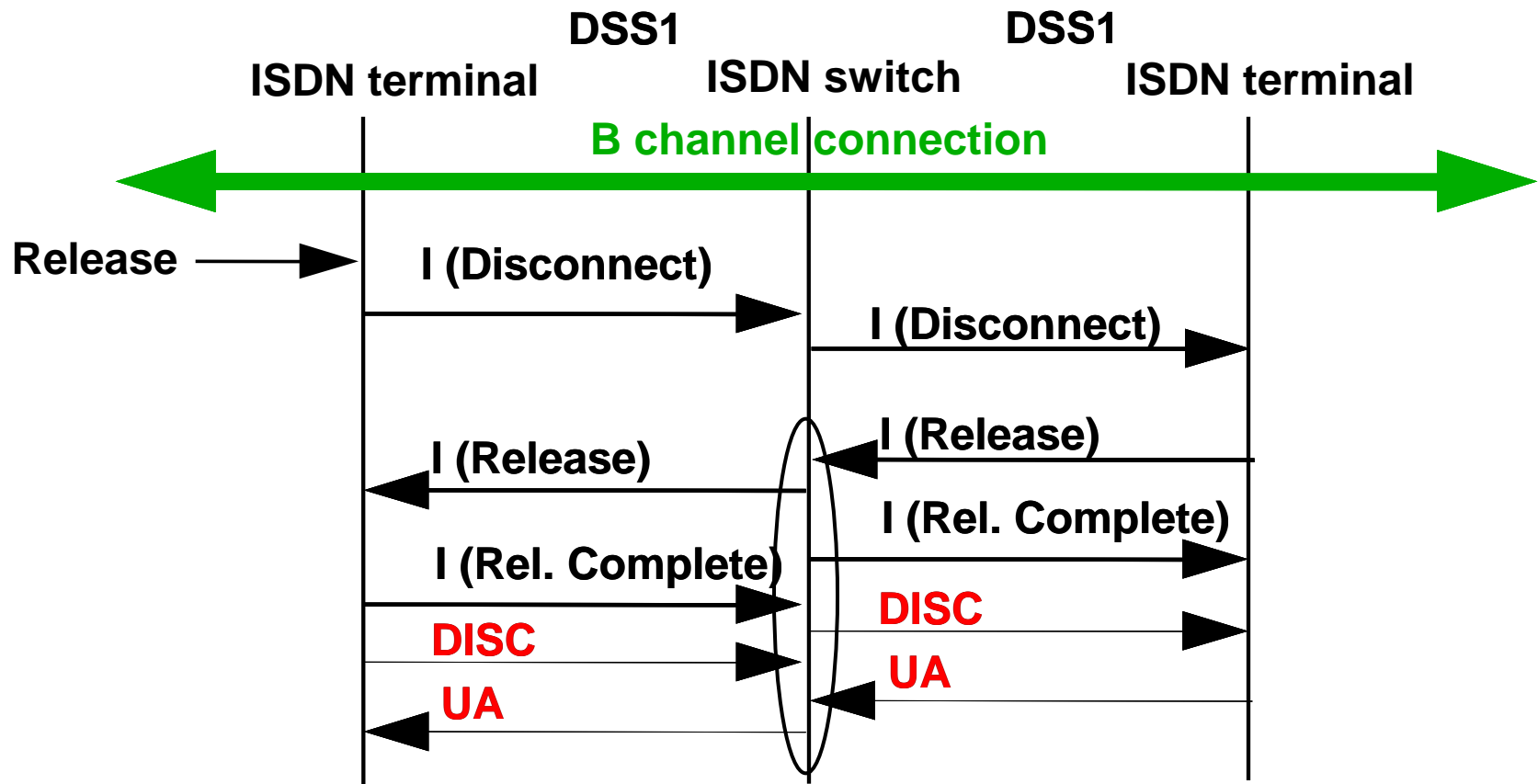

- Release processes: in parallel
- Release process can be started by any of the parties

Signalling

□ 6. Signalling

- 6.1 Overview
- 6.2 Subscriber signalling
- **6.3 Inter-switch signalling (SS7)**
- 6.4 GSM signalling

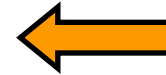

Channel Associated Signalling

- Originally: analogue systems
 - or in the voice channel itself – in-band signalling
 - or in a signalling channel associated to the voice line – out-of-band signalling
- Later: digital
 - Signalling bits in a signalling channel associated to the voice line (PCM signalling channel) – out-of-band signalling

Channel Associated Signalling

- Advantages:
 - simple
 - relation between signal and voice channel is obvious
- Disadvantages:
 - limited signalling transfer capability
 - signal transfer is not protected
- No non-call-related signal

Common Channel Signalling Systems

- Digital signals on a dedicated signalling channel that is independent from the voice channel
- Idea: not to occupy a voice channel for several, short (~100 byte) signals
- Advantages:
 - better utilisation of voice circuits
 - more complicated signals: lot of services can be controlled
 - signal transfer can be protected more than voice transfer
 - internal (e.g. management) messages possible
 - non-voice-related (e.g. data base query) signals possible (!!!!!)
- Disadvantages:
 - separated signalling network → plus cost
 - more complicated functioning of switches, etc.
 - voice path to be established separately – may be checked (call continuity control)
- More advantages...

Common Channel Signalling Systems

□ Separate signalling network

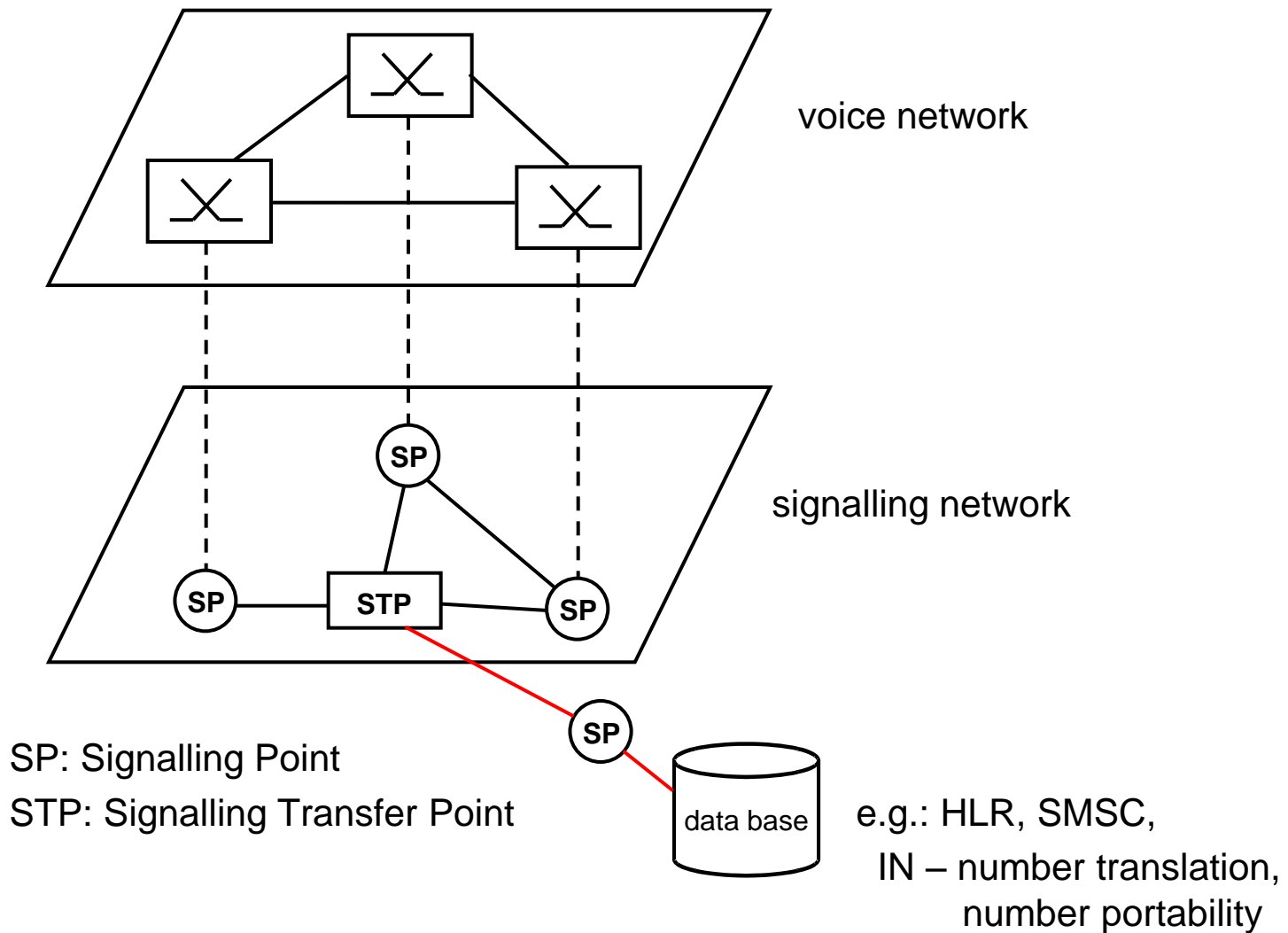

(CC)SS7

- „The” Common Channel Signalling System: SS7
- SS7 = (Common Channel) Signalling System No. 7,
- OSI-like architecture:

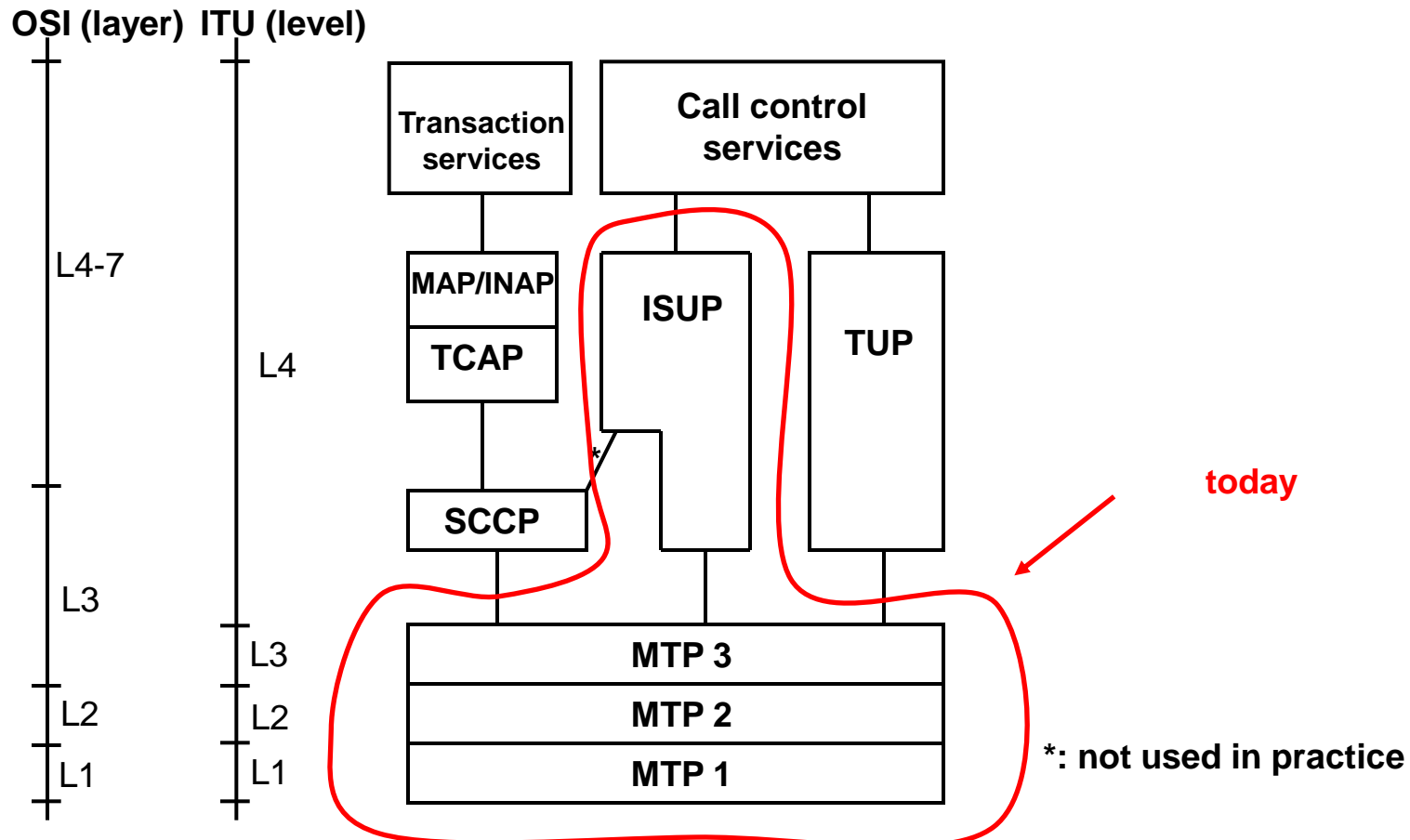

- MTP: Message Transfer Part
- MTP-1: physical level -- 64 kbps digital channel
- MTP-2: framing, error free transmission between neighbouring points
 - 3 types of signalling messages:
 - MSU, Message Signal Unit – carries signals from UPs (e.g. call control)
 - FISU, Fill-In Signal Unit
when no „useful” signal to be sent – empty signal to maintain synchronisation + acknowledgement
 - LSSU, Link Status Signal Unit – used to indicate the status of the link – processed by SNM

- MTP-3: message transfer between any two signalling points within a signalling network (remember: national, nat. interconnectiong, international networks)
 - two ends of every voice circuit always in the same network
 - problem in GSM: SCCP will be the solution
 - + Signalling Network Management

- TUP: Telephony User Part
 - withdrawn → ISUP
- ISUP: ISDN User Part
 - call control/release messages with a lot of parameters
 - circuit supervision
- SCCP: Signalling Connection Control Part
 - inter-network signalling
 - used in mobile systems
 - Global Titles (typically tel. numbers)
- TCAP: Transaction Capabilities Application Part
 - data base transactions (e.g. in GSM)
- MAP: Mobile Application Part
- INAP: Intelligent Network Application Part

ISUP call establishment/release

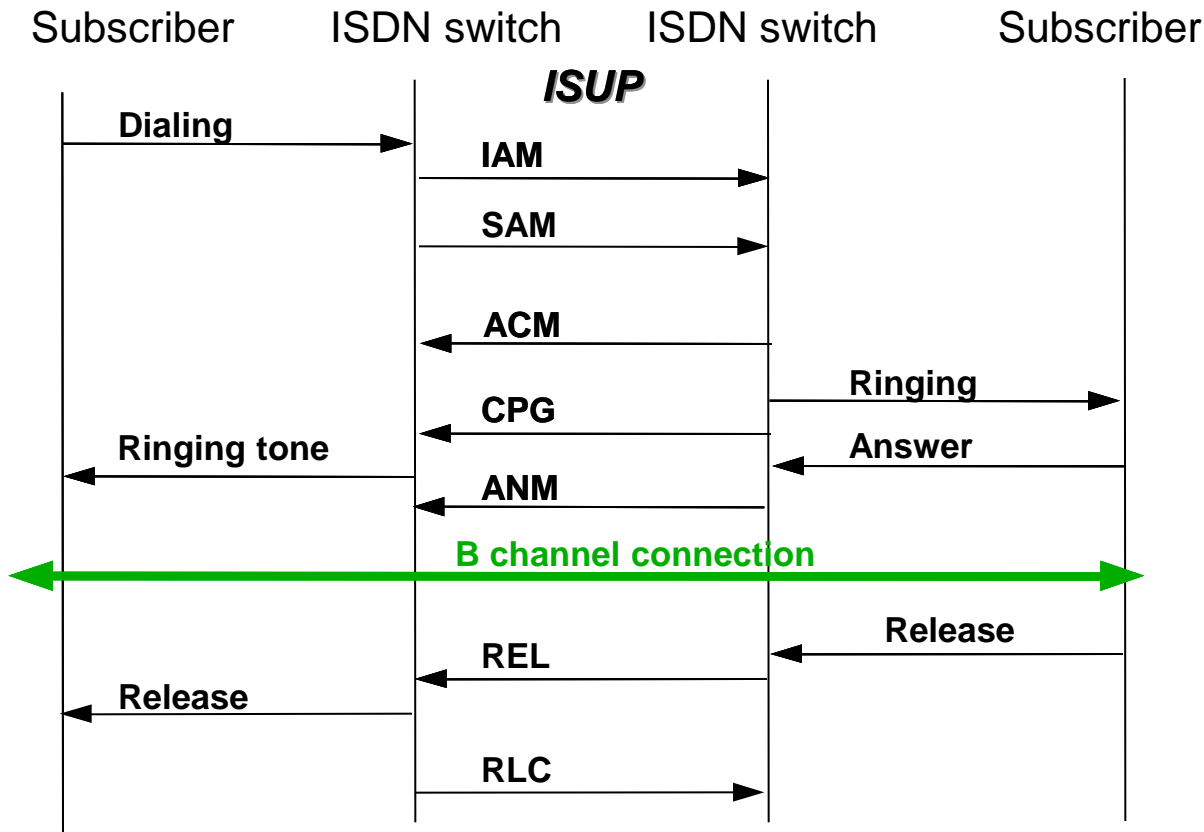

IAM: Initial Address Message,
SAM: Subsequent Address Message,
ACM: Address Complete

CPG: Call (in) Progress,
ANM: Answer Message
REL: Release
RLC: Release Complete

DSS1 + ISUP

