

Hálózatok építése és üzemeltetése

OSPF gyakorlat

Ismétlés

Routing protokollok

▶ Feladatuk

- ▶ optimális útvonal (next hop) kiszámítása bármely csomópontok között
 - ▶ aktuális állapot információ gyűjtés a hálózatról
 - ▶ útvonalak kalkulálása
- ▶ forwarding táblák
 - ▶ konfigurálása
 - ▶ dinamikus karbantartása, frissítése
 - ▶ bejövő routing protokoll üzenetek alapján
- ▶ routing információk
 - ▶ feldolgozása
 - ▶ terjesztése

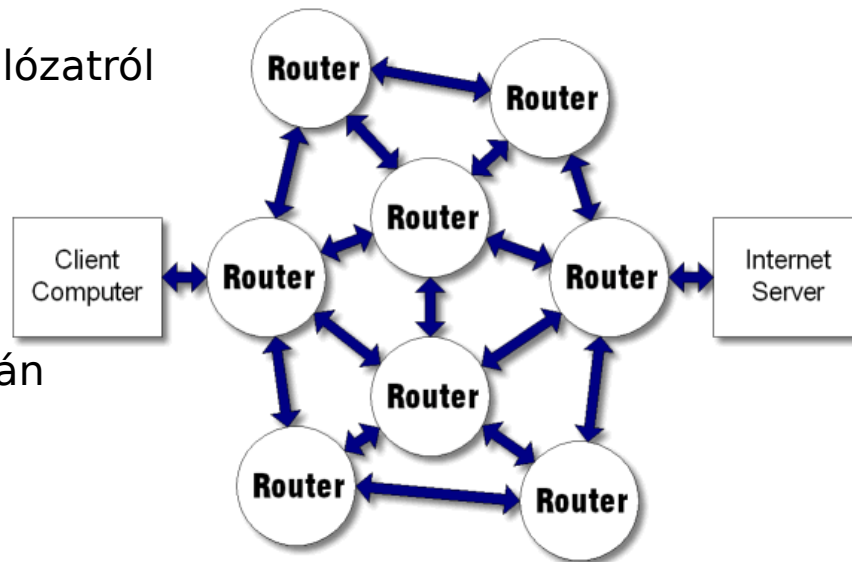

Routing protokollok

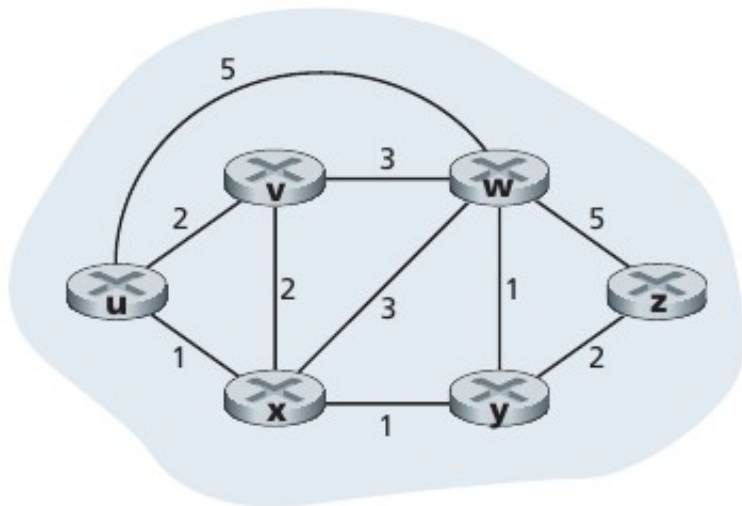

- ▶ Hálózat: absztrakt gráf
 - ▶ csomópontok: routerek
 - ▶ élek: linkek
 - ▶ élköltség: valamilyen metrika (pl. késleltetés, sávszélesség kifejezése)
- ▶ cél:
 - ▶ (valamilyen értelemben) optimális, legkisebb költségű útvonal meghatározása két csomópont között
 - ▶ pl. legrövidebb út
- ▶ Ismerős algoritmusok:
 - ▶ Dijkstra algoritmus
 - ▶ Bellman-Ford algoritmus

Csoportosításuk

▶ Globális vs. Elosztott

- ▶ globális: minden router ismeri a teljes topológiát
- ▶ elosztott: minden router csak a szomszédjait és a tőlük kapott üzeneteket ismeri

▶ Intra-domain vs. Inter-domain

▶ intra: Interior Gateway Protocol (IGP)

- ▶ közös adminisztratív domain
- ▶ rugalmatlan szabályok
- ▶ egyes esetekben nem jól skálázódik

▶ inter: Exterior Gateway Protocol (EGP)

- ▶ külön adminisztratív domaineik, AS-ek (Autonomous System) között
- ▶ jól skálázódik (internet)

▶ Link state vs. Distance Vector (ld. később)

Csoportosításuk

- ▶ Interior Gateway Protocol (IGP) példák
 - ▶ OSPF (OpenShortest Path First)
 - ▶ IS-IS (Intermediate System to Intermediate System)
 - ▶ RIP (Routing Information Protocol)
 - ▶ EIGRP (Enhanced Interior Gateway Routing Protocol)
- ▶ Exterior Gateway Protocol (EGP)
 - ▶ BGP (Border Gateway Protocol)
 - ▶ Id. MSC (Internet architektúra és szolgáltatások főspecializáció)

Link State alapú routing

- ▶ Működési elv
 - ▶ globális nézetten dolgozik
 - ▶ LSP: Link State Packet (id, costs, seq.no, ttl)
 - ▶ egy router
 - ▶ mindenkinek küld LSP-t (broadcast)
 - ▶ a közvetlenül kapcsolódó linkjeiről
 - ▶ periodikusan újra generálja (seq.no++)
 - ▶ legfrissebb beérkezett LSP-eket tárolja
 - ▶ mindenki ugyanazt a topológiát látja
 - ▶ azon számolja az útvonalakat
 - ▶ útvonalszámítás: Dijkstra algoritmus

Például: OSPF

- ▶ Open Shortest Path First (v2)
- ▶ nyílt, IETF szabvány
 - ▶ v2: RFC 2328
 - ▶ IP felett
- ▶ együttműködés különböző gyártók termékei között!
- ▶ korlátozott erőforrás igény
- ▶ viszonylag gyors, automatikus konvergencia topológia változásokra
- ▶ támogatja
 - ▶ különböző útvonal költségek számítását
 - ▶ hierarchikus, többszintű topológiát
 - ▶ alkalmazás típusára alapozott forgalomirányítást
 - ▶ autentikációt minden üzenetre

Hálózatemulációs környezet

Netkit, Quagga

Netkit

The poor man's system for experimenting
computer networking

Version	2.3
Author(s)	G. Di Battista, M. Patrignani, M. Pizzonia, M. Rimondini
E-mail	contact@netkit.org
Web	http://www.netkit.org/
Description	an introduction to the architecture, setup, and usage of Netkit

Újabb platformjuk:

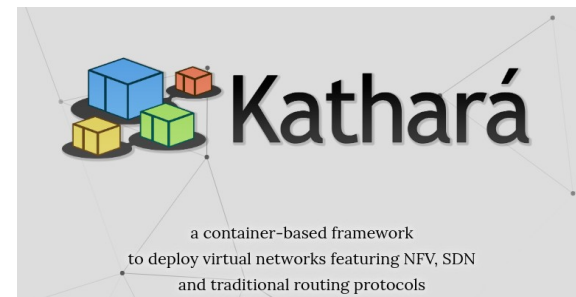

netkit: a system for emulating computer networks

- based on uml (user-mode linux)
 - <http://user-mode-linux.sourceforge.net/>
- each emulated network device is a virtual linux box
 - a virtual linux box is one that is based on the uml kernel
- note: the linux os is shipped with software supporting most of the network protocols
 - hence, any linux machine can be configured to act as a bridge/switch or as a router

Netkit

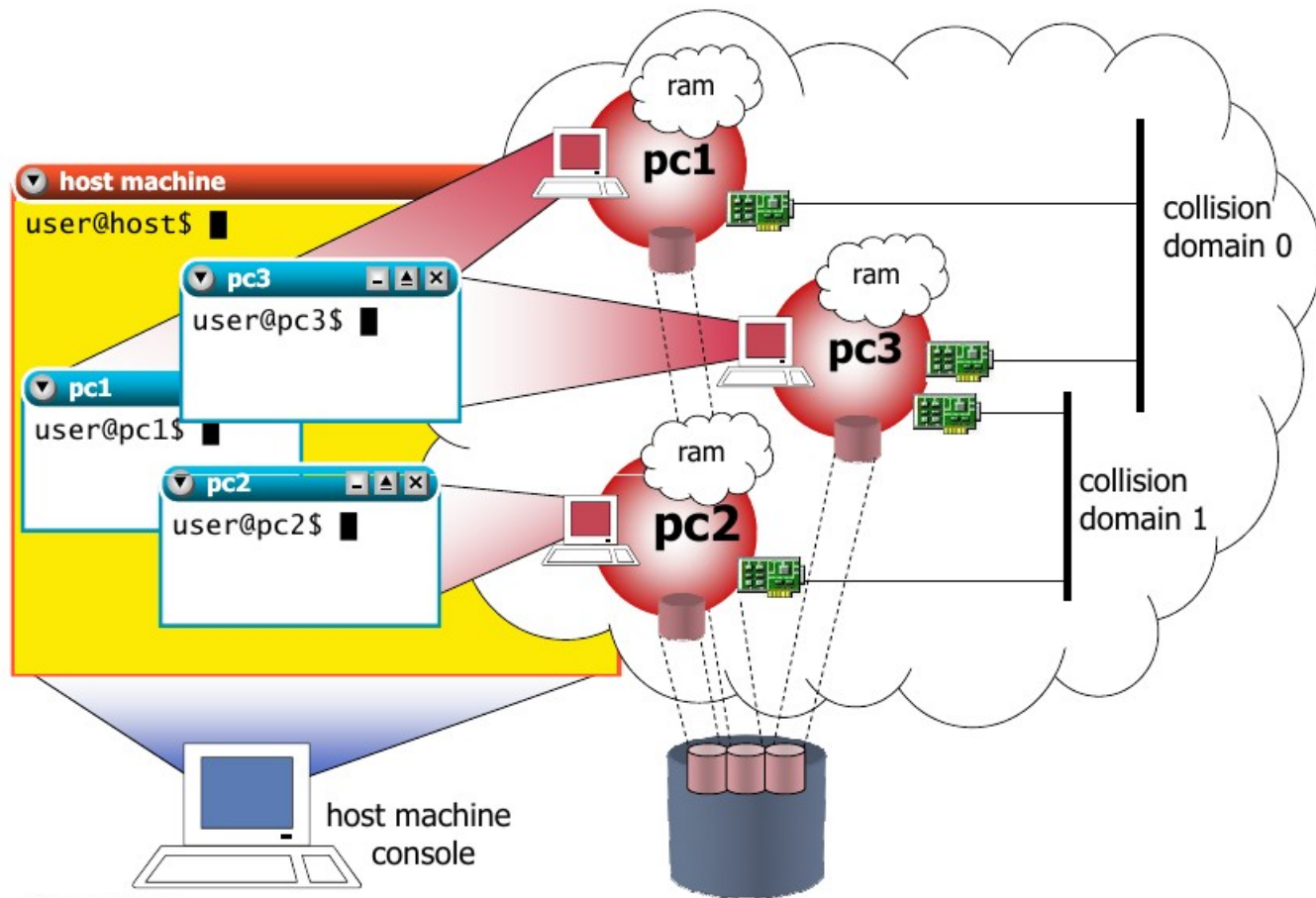

netkit vcommands

- allow to startup virtual machines with arbitrary configurations (memory, network interfaces, etc.)
 - **vstart**: starts a new virtual machine
 - **vlist**: lists currently running virtual machines
 - **vconfig**: attaches network interfaces to running vms
 - **vhalt**: gracefully halts a virtual machine
 - **vcrash**: causes a virtual machine to crash
 - **vclean**: “panic command” to clean up all netkit processes (including vms) and configuration settings on the host machine

netkit lcommands

- ease setting up complex labs consisting of several virtual machines
 - **lstart**: starts a netkit lab
 - **lhalt**: gracefully halts all vms of a lab
 - **lcrash**: causes all the vms of a lab to crash
 - **lclean**: removes temporary files from a lab directory
 - **linfo**: provides information about a lab without starting it
 - **ltest**: allows to run tests to check that the lab is working properly

Quagga/Zebra

- ▶ Routing Szoftver csomag
 - ▶ GPL
 - ▶ FreeBSD, Linux, Solaris, NetBSD
 - ▶ GNU Zebra volt előbb
 - ▶ Quagga egy fork volt
 - ▶ “The Quagga tree aims to build a more involved community around Quagga than the current centralised model of GNU Zebra.”
 - ▶ az élővilágban a quagga halt ki
 - ▶ a routing világban a zebra

Quagga/Zebra

- ▶ Routing Szoftver csomag
 - ▶ zebra (core daemon)
 - ▶ kernel interface, static routes
 - ▶ zserv szerver (API) -> quagga kliensek felé
 - ▶ quagga démonok
 - ▶ routing protokollok
 - ripd, ripngd, ospfd, ospf6d, bgpd, isisd
 - ▶ mindegyikkel dedikált CLI-n (vty) keresztül kommunikálhatunk
 - hasonló interfész, mint egy HW routernél
 - ▶ speciális quagga tool: vtysh
 - közös front-end minden démonhoz



zebra: a routing daemon

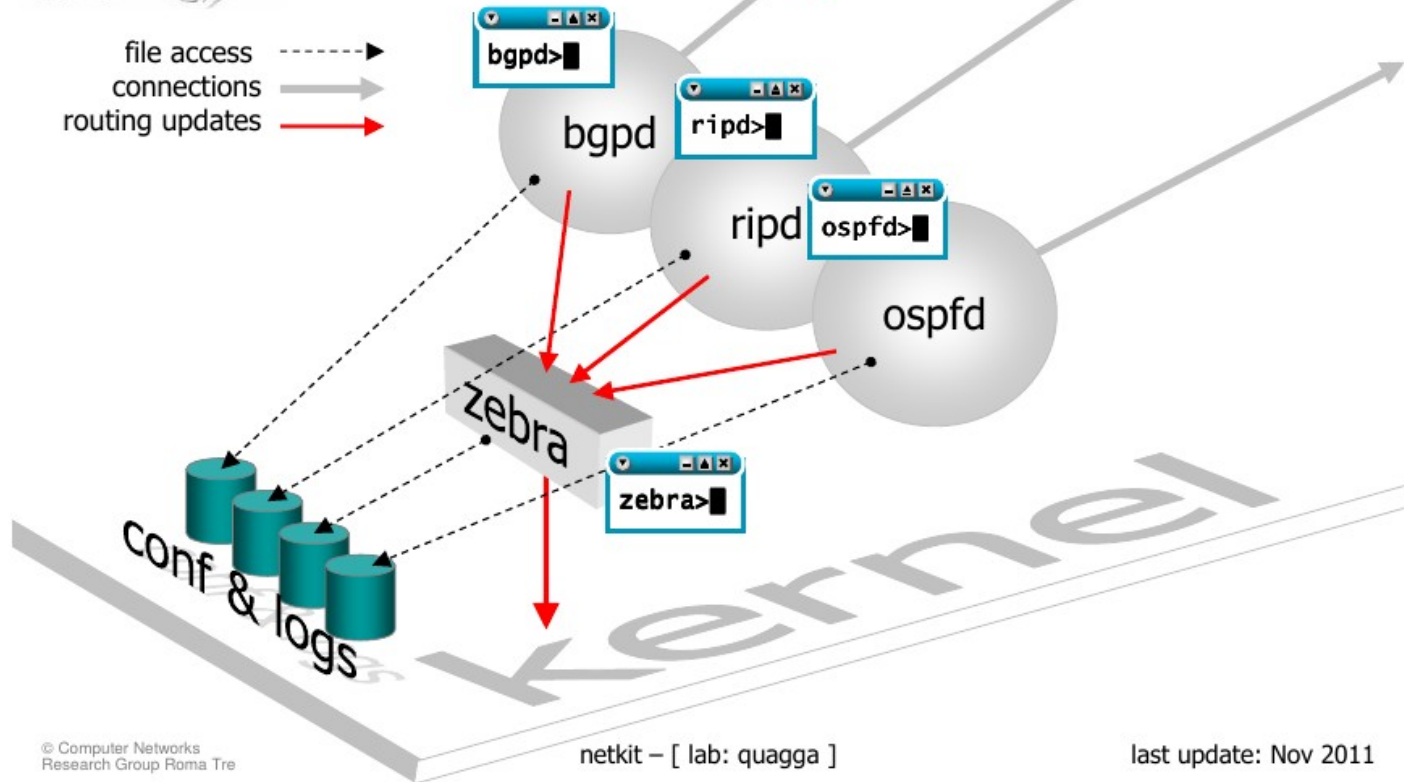

Vizsgálati környezet kialakítása

- ▶ **QBF12: BME Cloud (Smallville), template: HaEpUz 2021 ...**
- ▶ IB213 labor: default HaEpUz (Mininet+Netkit) boot image
- ▶ Saját gép:
 - ▶ Kiadott HaEpUz VM (Jupyter Notebook)
 - ▶ de most nem a notebookot használjuk
 - ▶ Indítás (importálás): Virtualbox vagy VMware player
- ▶ A rendszer egy Ubuntu 64-bit Linux + desktop environment, tartalma:
 - ▶ Mininet hálózatemuláció
 - ▶ Netkit hálózatemuláció
- ▶ OSPF lab indítása:
 - ▶ `$ cd ~/netkit/labs/netkit-lab_ospf-singlearea`
 - ▶ `$ Istart`

BME Cloud (Smallville)

HaEpUz 2021 - Ubuntu 20.04 + xfce4 v7 cloud-40082.vm.smallville.cloud.bme.hu ☆



RUNNING

Connection details

Protocol SSH
Host vm.smallville.cloud.bme.hu:13202
Host (IPv6) cloud-40082.vm.smallville.cloud.bme.hu:22
Username cloud
Password

[Generate new password!](#)

Command

[Connect \(download client\)](#)

Home Resources Console Access **Network** Activity

Interfaces

[add interface](#)

VM-NET [remove](#)

IPv4 address: 10.9.1.210
IPv6 address: 2001:738:2001:2209:9:1:210:0
DNS name: cloud-40082.vm.smallville.cloud.bme.hu
Groups: -

Port access

	IPv4	IPv6
vm.smallville.cloud.bme.hu:13202	→ 22/tcp	×
vm.smallville.cloud.bme.hu:8852	→ 3389/tcp	×

add rdp

3389

/ tcp [Add](#)

haepuz-1 (unmanaged) [remove](#)

Belépés: rdp

(xfce4 desktop)

rdp kliens

- pl.: krdc, remmina, MS...

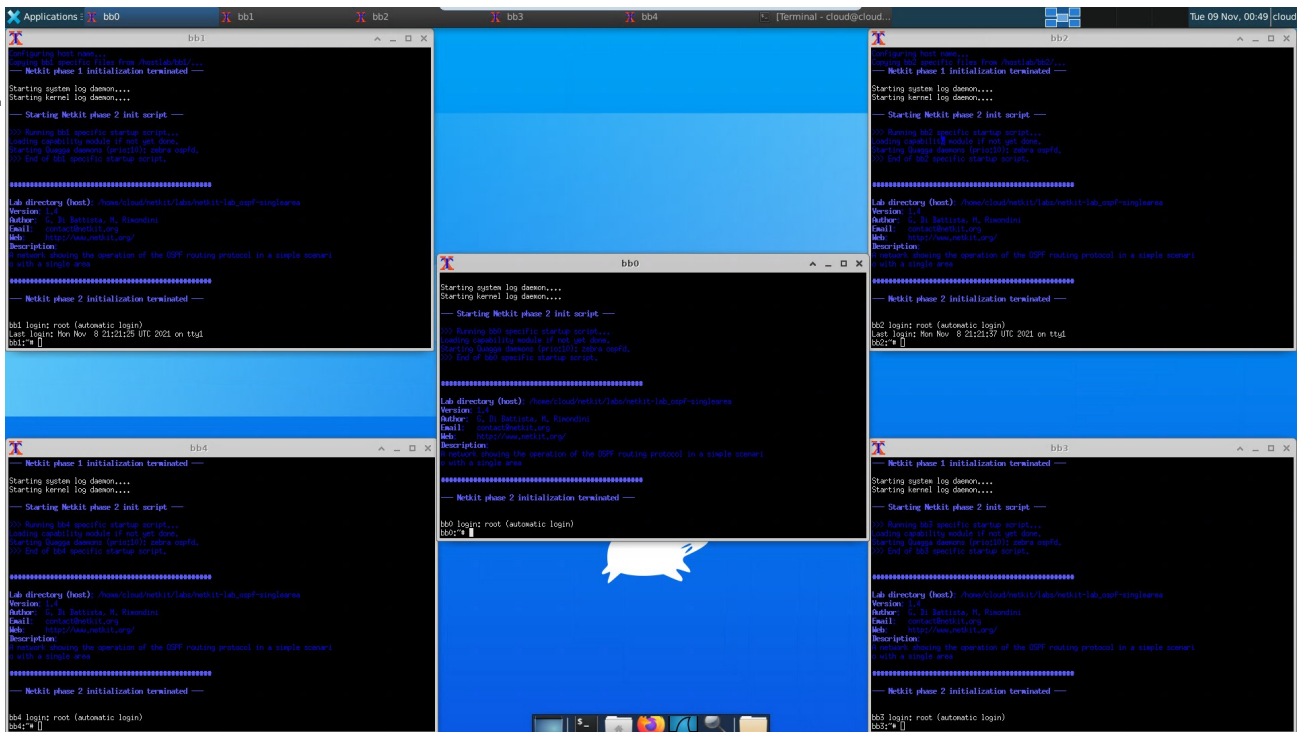
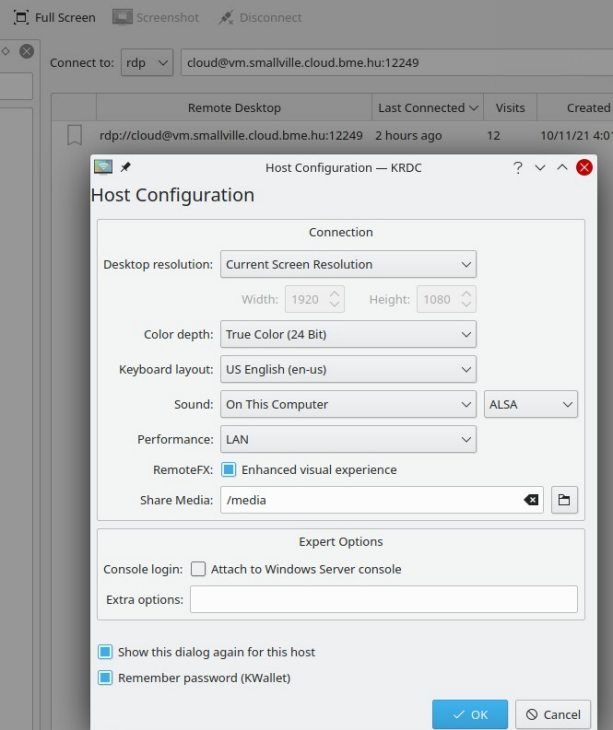

OSPF lab# 1

netkit-lab_ospf-singlearea

OSPF lab#1 topológia

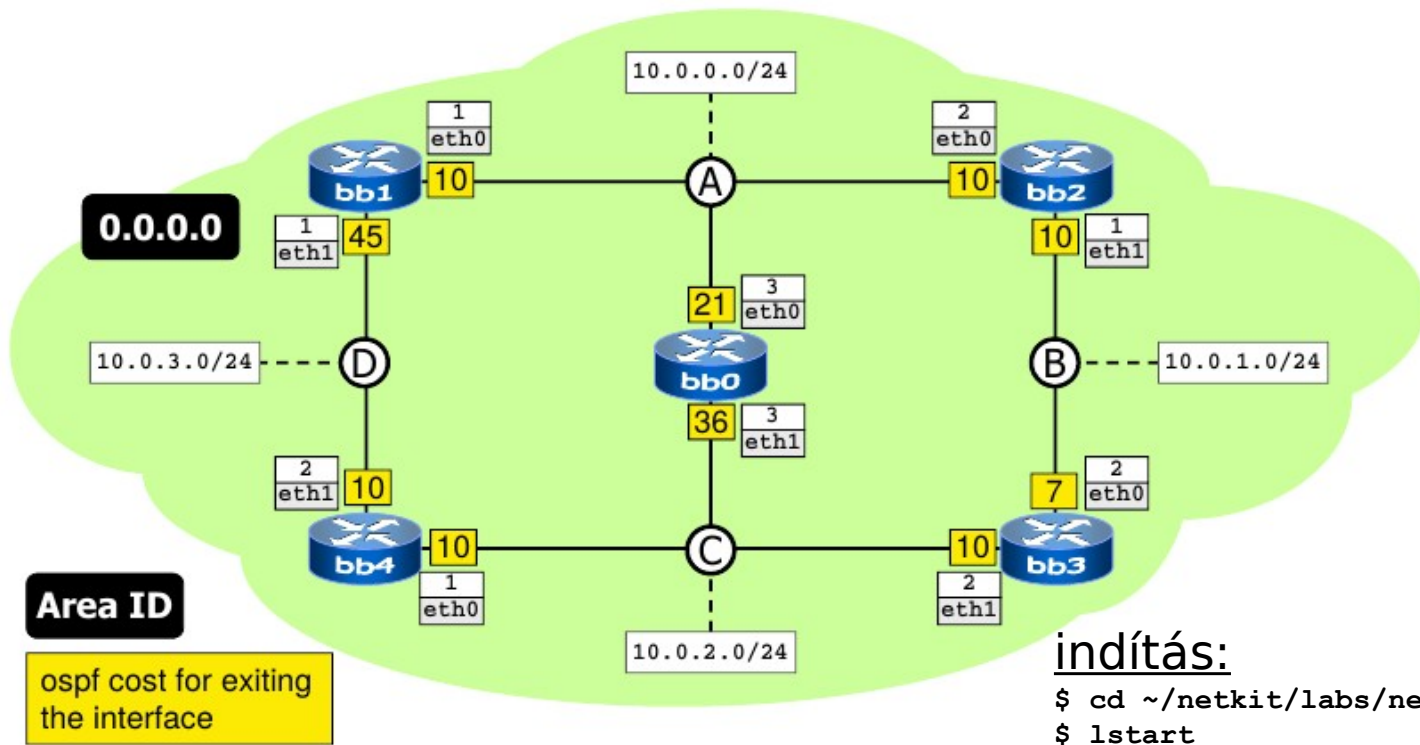

- ▶ single (backbone) area
 - ▶ 0.0.0.0
- ▶ minden interfészhez
 - ▶ ospf cost
 - ▶ default: 10
 - ▶ néha trükkösen van beállítva!

indítás:

```
$ cd ~/netkit/labs/netkit-lab_ospf-singlearea  
$ lstart
```

netkit - [labs: ospf]

last update: Nov 2014

OSPF lab#1 topológia

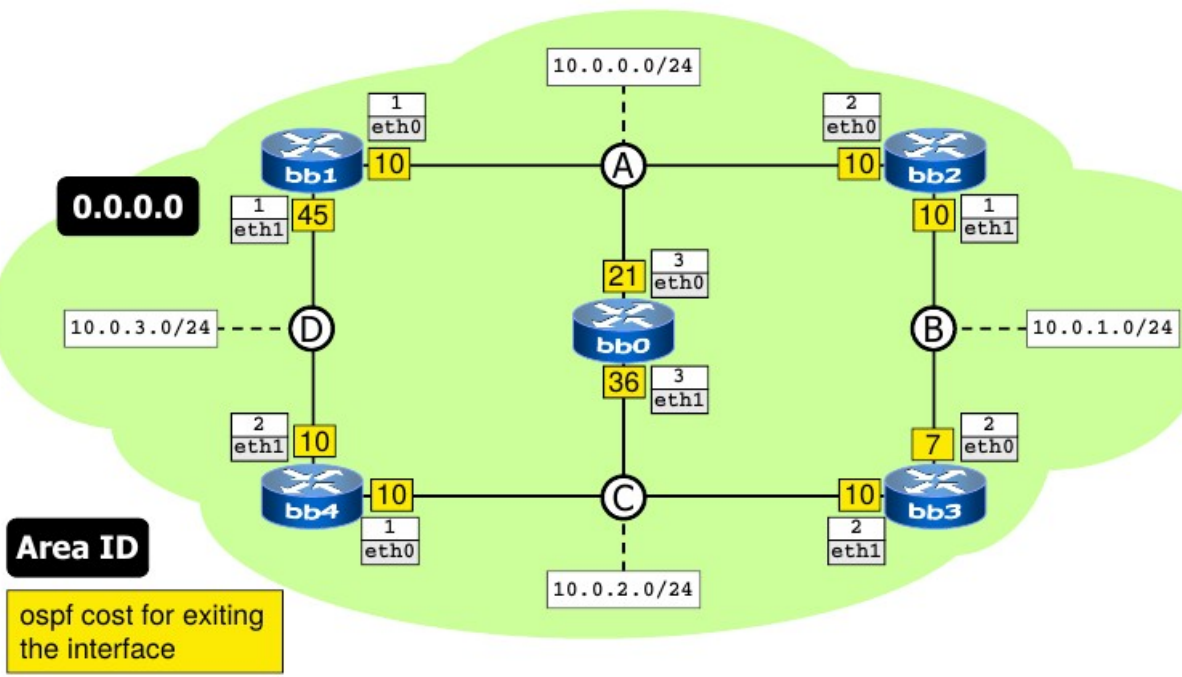

© Computer Networks
Research Group Roma Tre

netkit - [labs: ospf]

last update: Nov 20

- ▶ quagga teszt, pl. bb0 routeren
 - ▶ cd /etc/zebra; ls -l
 - ▶ daemon conf fájlok
 - ▶ cat daemons
 - ▶ cat zebra.conf (passwd!)
 - ▶ cat ospfd.conf

```
bb0:/etc/zebra# cat ospfd.conf
!
hostname ospfd
password zebra
enable password zebra
!
! Default cost for exiting an interface is 10
interface eth0
ospf cost 21
interface eth1
ospf cost 36
!
router ospf
! Speak OSPF on all interfaces falling in 10.0.0.0/16
network 10.0.0.0/16 area 0.0.0.0
redistribute connected
!
log file /var/log/zebra/ospfd.log
```

OSPF lab#1 topológia

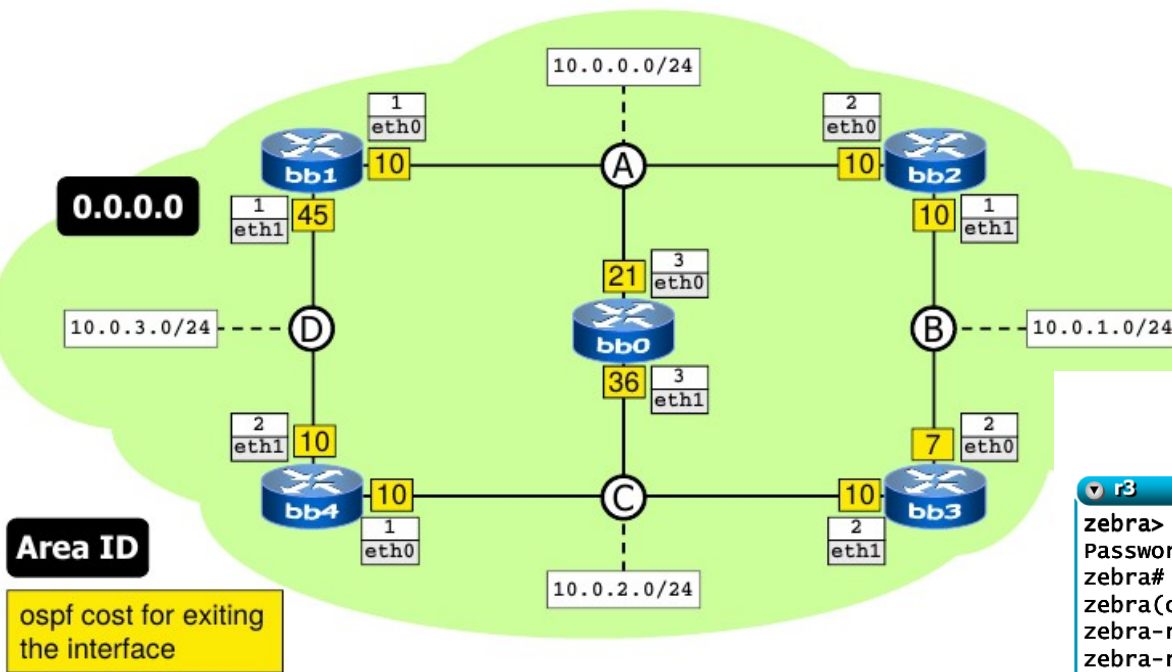

Area ID

ospf cost for exiting the interface

© Computer Networks Research Group Roma Tre

netkit - [labs: ospf] last u

- ▶ quagga teszt, pl. bb0 routeren
 - ▶ telnet localhost zebra
 - ▶ szokásos lehetőségek
 - enable, configure terminal, ?, <tab>, show, list
 - ▶ telnet localhost ospfd
 - ▶ show ip ospf
 - ▶ vttysh (minden démonhoz)

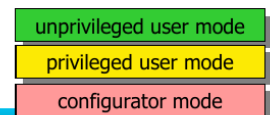

```
r3
zebra> enable
Password: zebra
zebra# configure terminal
zebra(config)# hostname zebra-r3
zebra-r3(config)# password foo
zebra-r3(config)# enable password foo
zebra-r3(config)# quit
zebra-r3# write file
Configuration saved to /etc/zebra/zebra.conf
zebra-r3# disable
zebra-r3> exit
Connection closed by foreign host.
r3:~#
```

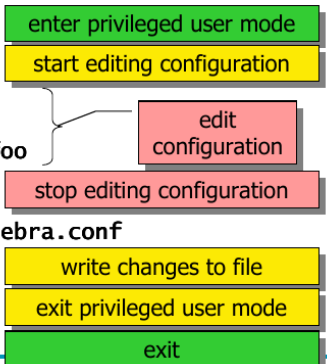

Legrövidebb utak

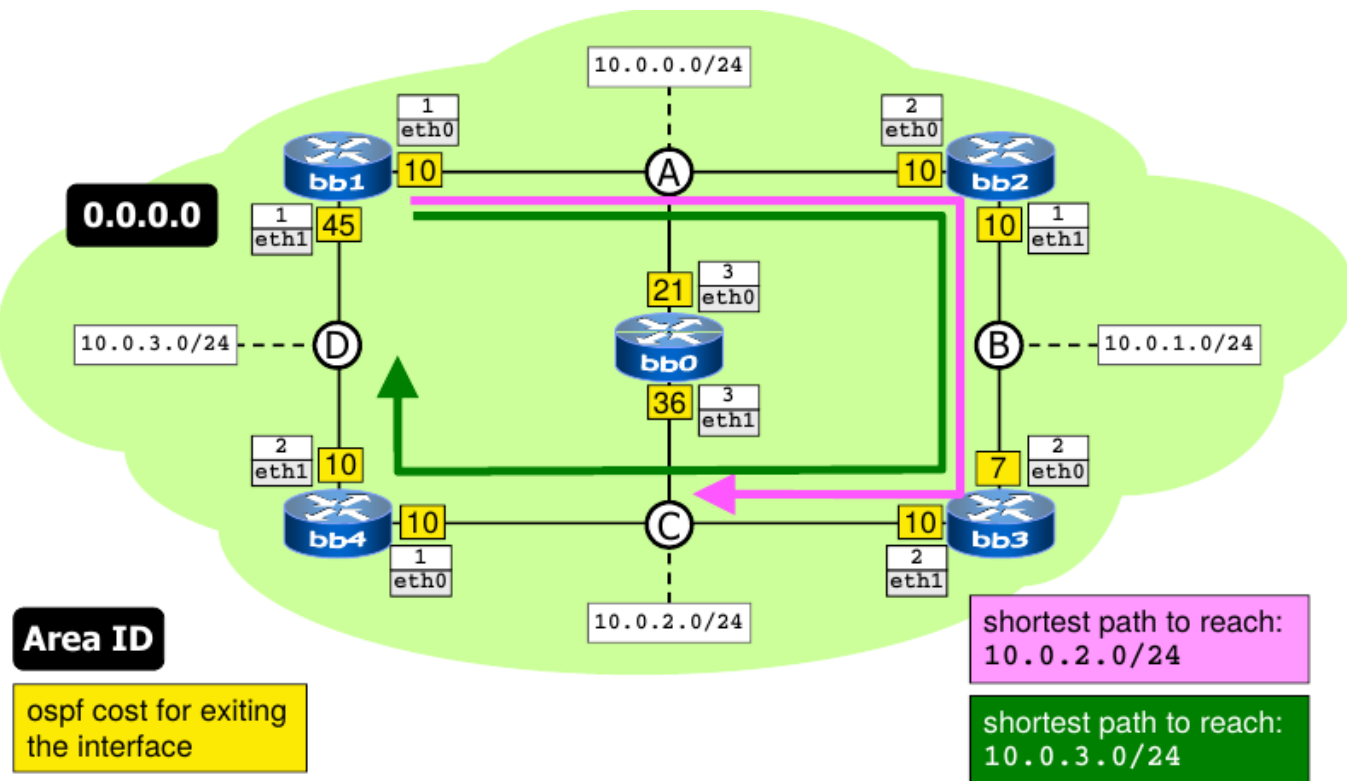

- ▶ traceroute -l icmp
 - ▶ bb1->10.0.2.1
 - ▶ melyik útvonal?
 - ▶ hogy jönnek vissza az ICMP válaszok?
 - ▶ bb1->10.0.3.2
 - ▶ melyik útvonal?

Legrövidebb utak

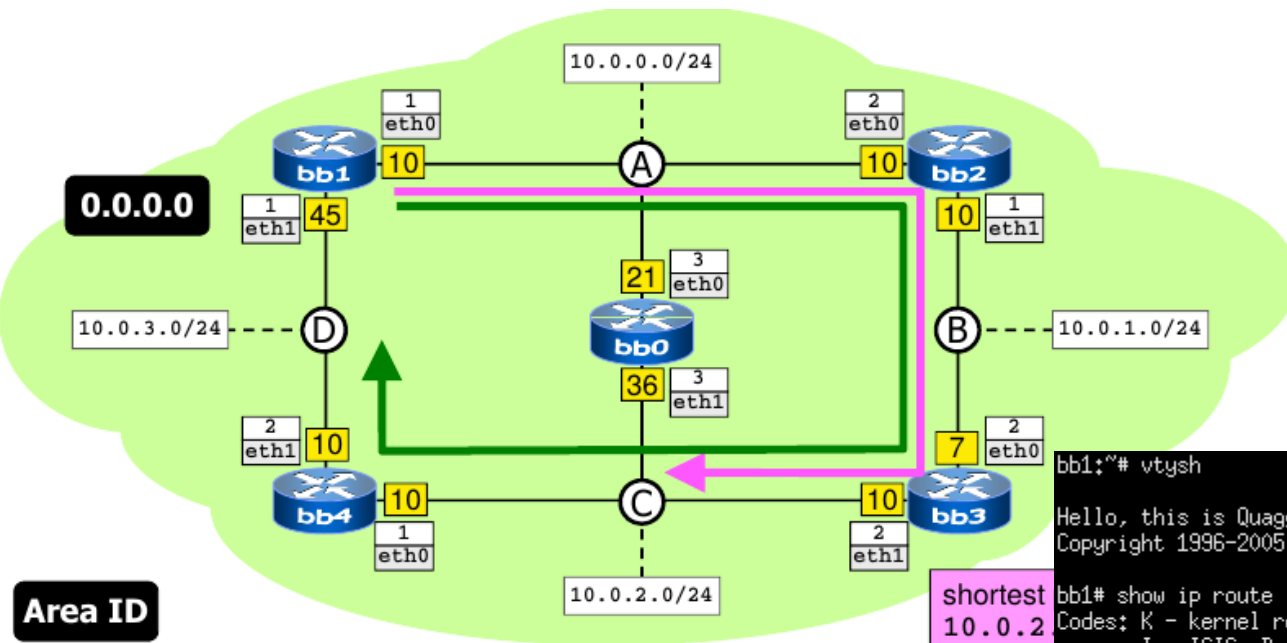

- ▶ routing táblák
 - ▶ értelmezzük minden routeren
 - ▶ vtysh
 - ▶ show ip route
 - ▶ administrative distance: 110 (default OSPF)
 - ▶ ospf metric: 10, 20, ...
 - ▶ connected metric: 1

Area ID

ospf cost for exiting the interface

```
bb1:~# vtysh
```

```
Hello, this is Quagga (version 0.99.10).  
Copyright 1996-2005 Kunihiro Ishiguro, et al.
```

```
bb1# show ip route
```

```
Codes: K - kernel route, C - connected, S - static, R - RIP, O - OSPF,  
I - ISIS, B - BGP, > - selected route, * - FIB route
```

```
shortest
```

```
10.0.2
```

```
shortest
```

```
10.0.3
```

```
O 10.0.0.0/24 [110/10] is directly connected, eth0, 00:53:10  
C>* 10.0.0.0/24 is directly connected, eth0  
O>* 10.0.1.0/24 [110/20] via 10.0.0.2, eth0, 00:53:05  
O>* 10.0.2.0/24 [110/30] via 10.0.0.2, eth0, 00:53:05  
O 10.0.3.0/24 [110/40] via 10.0.0.2, eth0, 00:53:05  
C>* 10.0.3.0/24 is directly connected, eth1  
C>* 127.0.0.0/8 is directly connected, lo  
bb1#
```



Legrövidebb utak

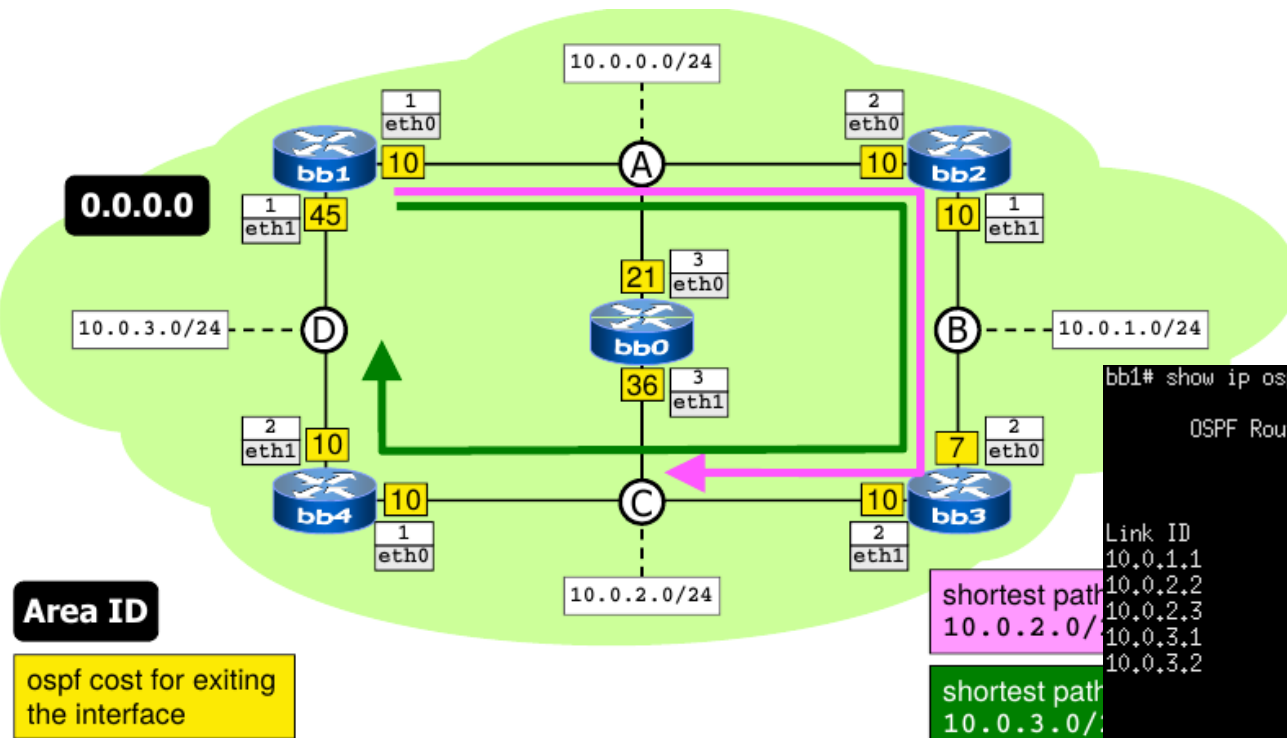

- ▶ ospf vizsgálata
- ▶ nézzük meg minden routeren
- ▶ vtysh
- ▶ show ip ospf database
- ▶ show ip ospf neighbor
- ▶ show ip ospf route

```
bb1# show ip ospf database
```

```
OSPF Router with ID (10.0.3.1)
```

```
Router Link States (Area 0.0.0.0)
```

Link ID	ADV Router	Age	Seq#	CkSum	Link count
10.0,1,1	10.0,1,1	473	0x80000007	0xe1fe	2
10.0,2,2	10.0,2,2	474	0x80000007	0xdbfe	2
10.0,2,3	10.0,2,3	473	0x8000000a	0xd9d4	2
10.0,3,1	10.0,3,1	467	0x8000000a	0x248f	2
10.0,3,2	10.0,3,2	469	0x80000009	0x3e92	2

```
Net Link States (Area 0.0.0.0)
```

Link ID	ADV Router	Age	Seq#	CkSum
10.0,0,1	10.0,3,1	467	0x80000006	0x61ad
10.0,1,2	10.0,2,2	474	0x80000004	0x63be
10.0,2,1	10.0,3,2	468	0x80000006	0x6a9e
10.0,3,2	10.0,3,2	468	0x80000005	0x63b7

Speciális gráf modell

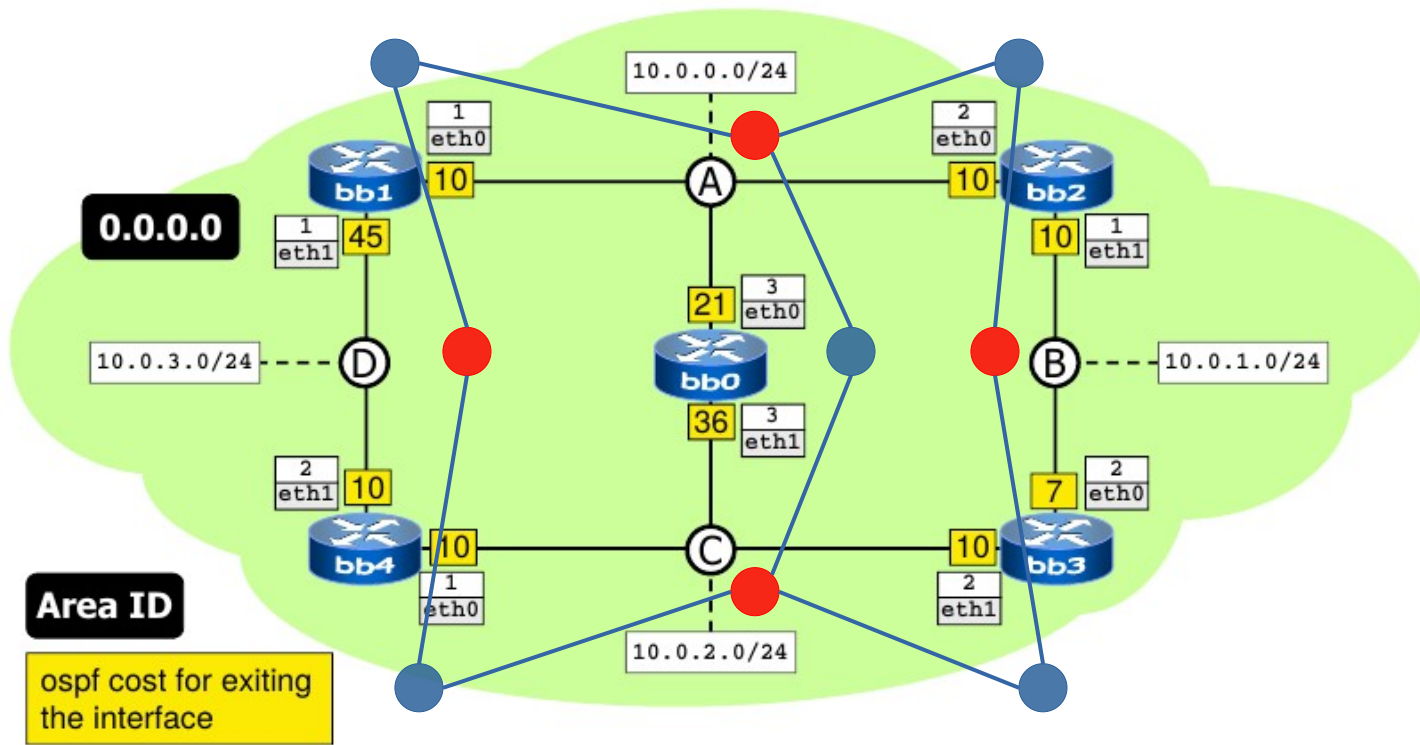

- ▶ Broadcast hálózatok
 - ▶ nem pont-pont linkek
 - ▶ pl. Ethernet
 - ▶ hálózat is csomópont

- ▶ pont-pont linkeknél
 - ▶ router-router él

Designated Router (DR) és BDR

(router interfaces designated for each network)

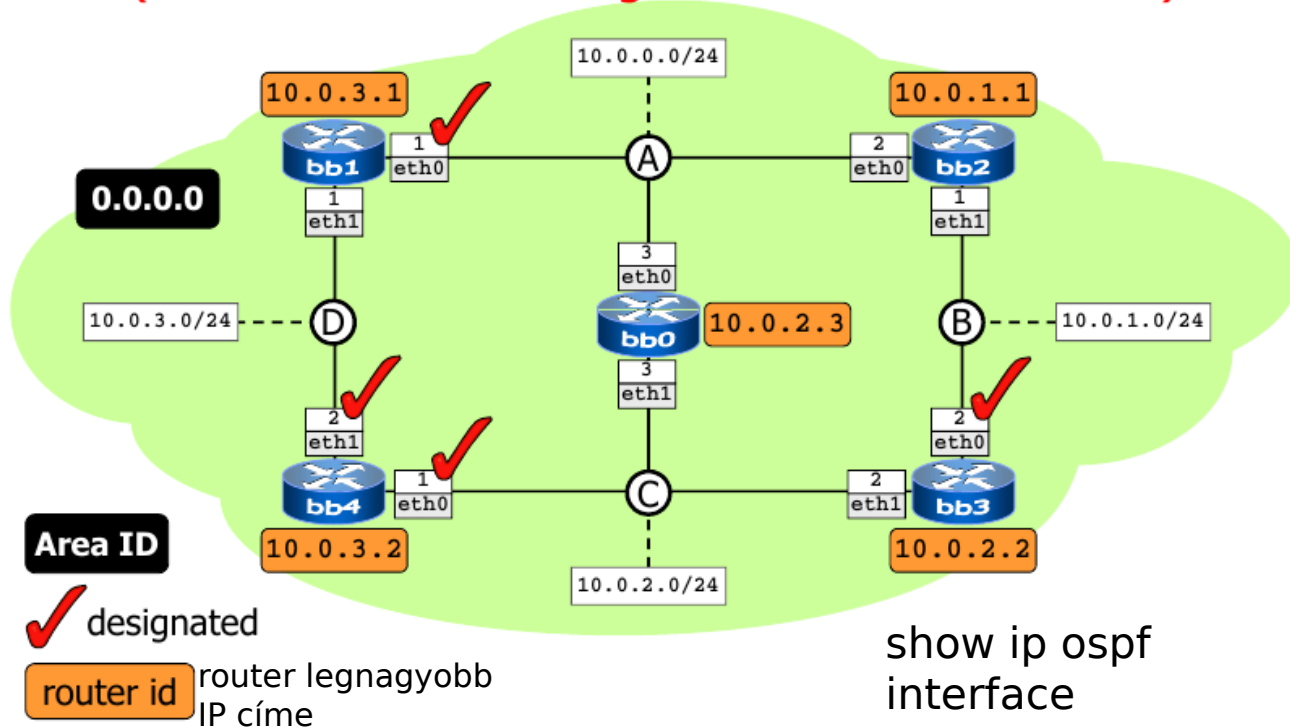

- ▶ Broadcast hálózatoknál
 - ▶ pl. Ethernet
 - ▶ DR és Backup DR: kitüntetett routerek
 - ▶ választás alapján
 - ▶ router id alapján (max.)
 - ▶ (ami interfész id)
 - ▶ többi OSPF router csak velük van full szomszédságban
 - ▶ különben mindenki-mindenkivel kommunikálna
 - ▶ útvonalfrissítés csak DR-től
 - ▶ sok erőforrás spórolható

ospf's view of the network

- by exchanging link state update packets, every router learns about the complete network topology, that is:
 - routers
 - subnets
 - adjacencies between routers and networks

ospf's view of the network

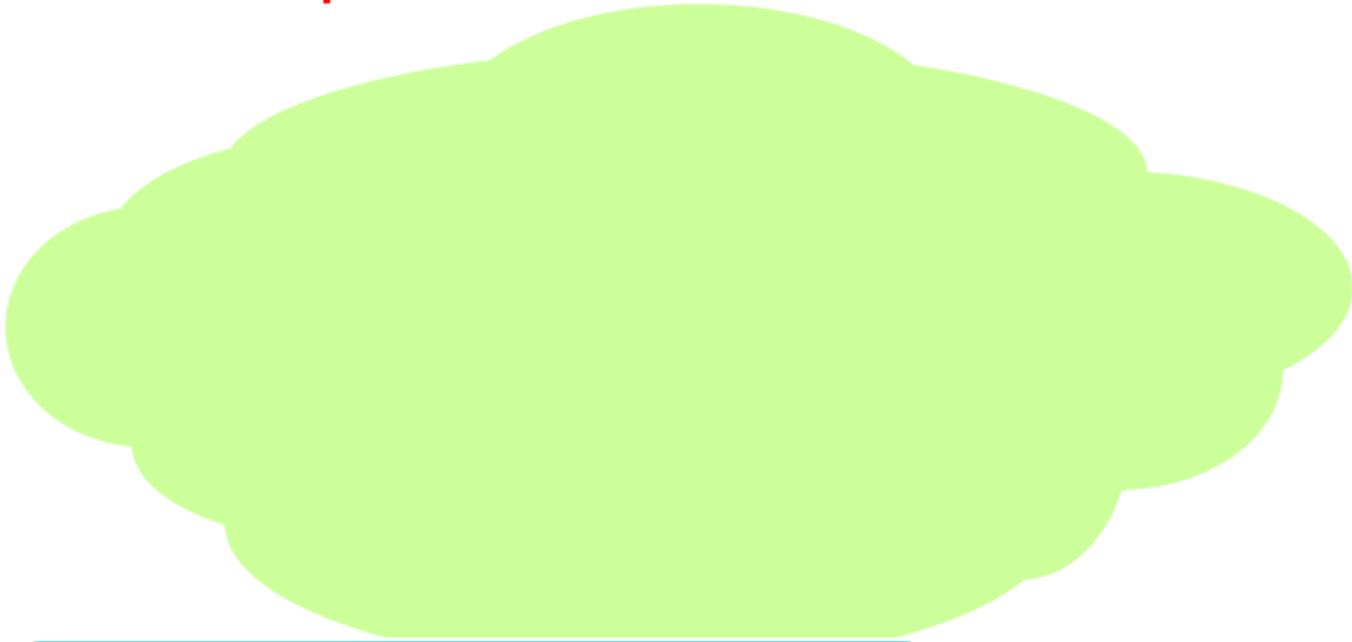

```
bb0  
bb0# show ip ospf database █
```

ospf's view of the network

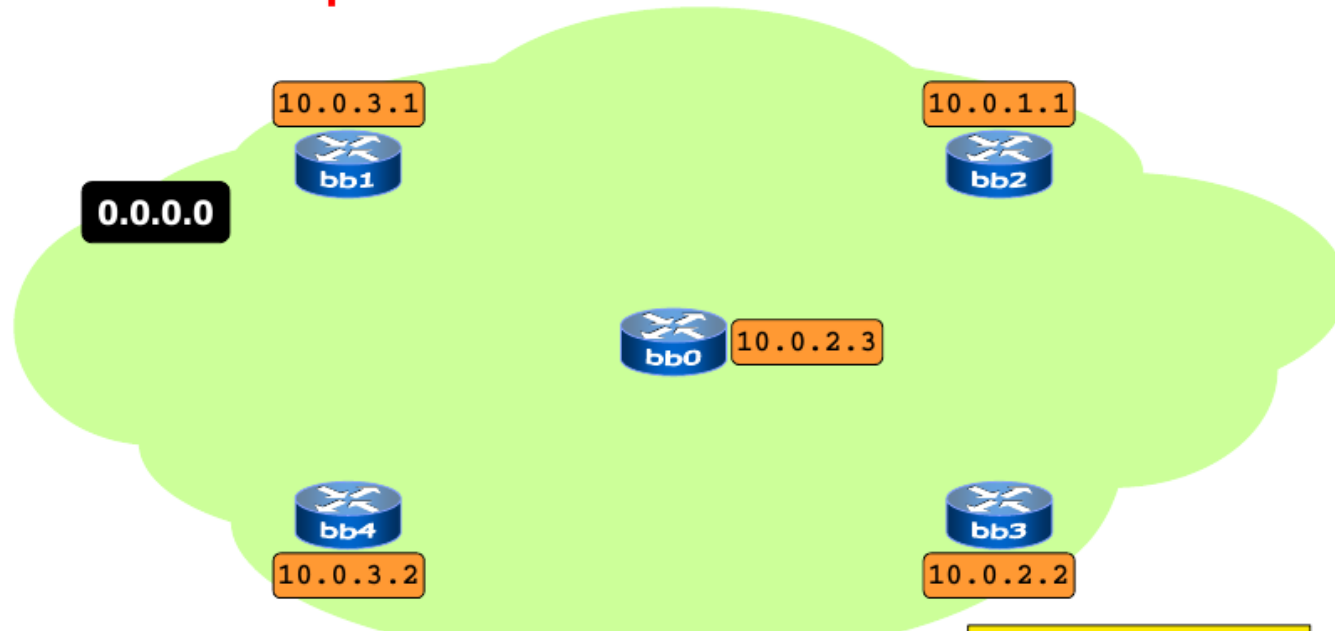

```
bb0
OSPF Router with ID (10.0.2.3)
Router Link States (Area 0.0.0.0)
Link ID      ADV Router   Age  Seq#       CkSum  Link count
10.0.1.1     10.0.1.1     553  0x80000003 0xe9fa 2
10.0.2.2     10.0.2.2     552  0x80000003 0xe3fa 2
10.0.2.3     10.0.2.3     552  0x80000003 0xe7cd 2
10.0.3.1     10.0.3.1     552  0x80000003 0x3288 2
10.0.3.2     10.0.3.2     548  0x80000004 0x488d 2
```

for router lsas,
the Link ID is
the router's id

router
legnagyobb IP
címe

last update: Nov 2014

ospf's view of the network

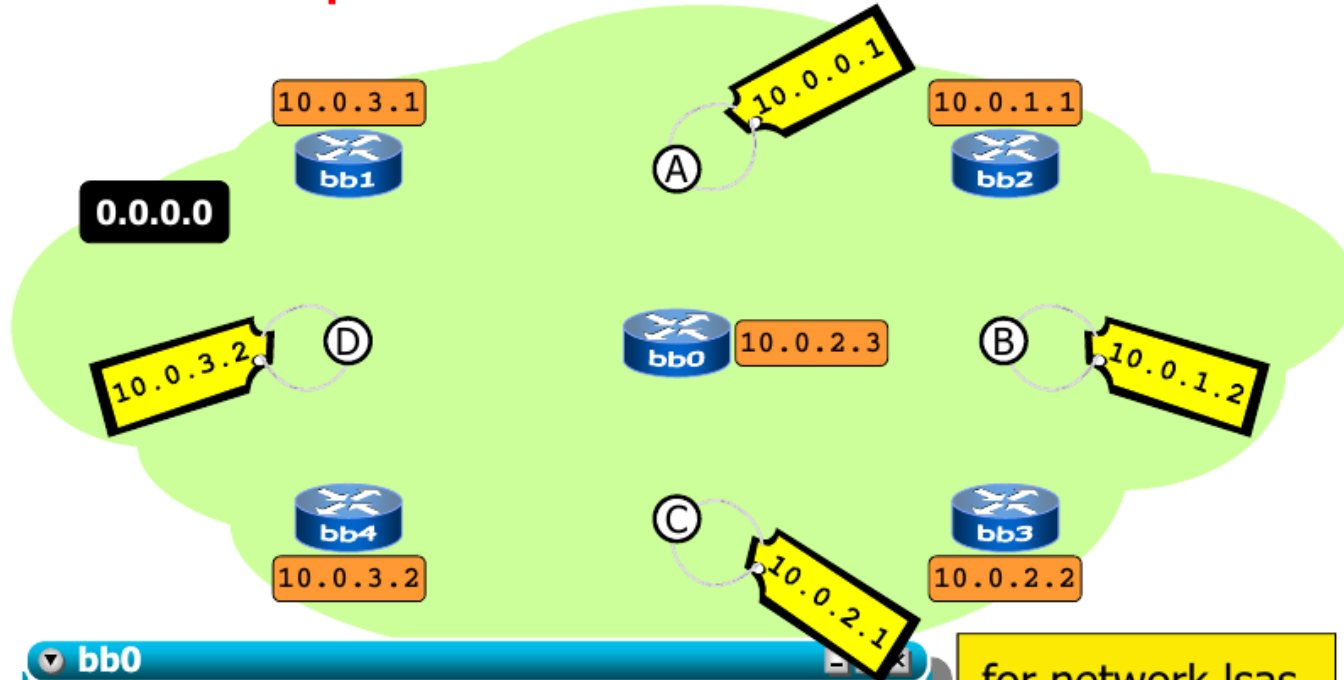

```
bb0
Net Link States (Area 0.0.0.0)
Link ID      ADV Router   Age  Seq#       CkSum
10.0.0.1     10.0.3.1    557  0x80000001 0x6ba8
10.0.1.2     10.0.2.2    559  0x80000001 0x69bb
10.0.2.1     10.0.3.2    553  0x80000002 0x729a
10.0.3.2     10.0.3.2    553  0x80000001 0x6bb3
```

for network lsas,
the Link ID is
the dr's address

DR IP címe
abban a
hálózatban

last update: Nov 2014



ospf's view of the network

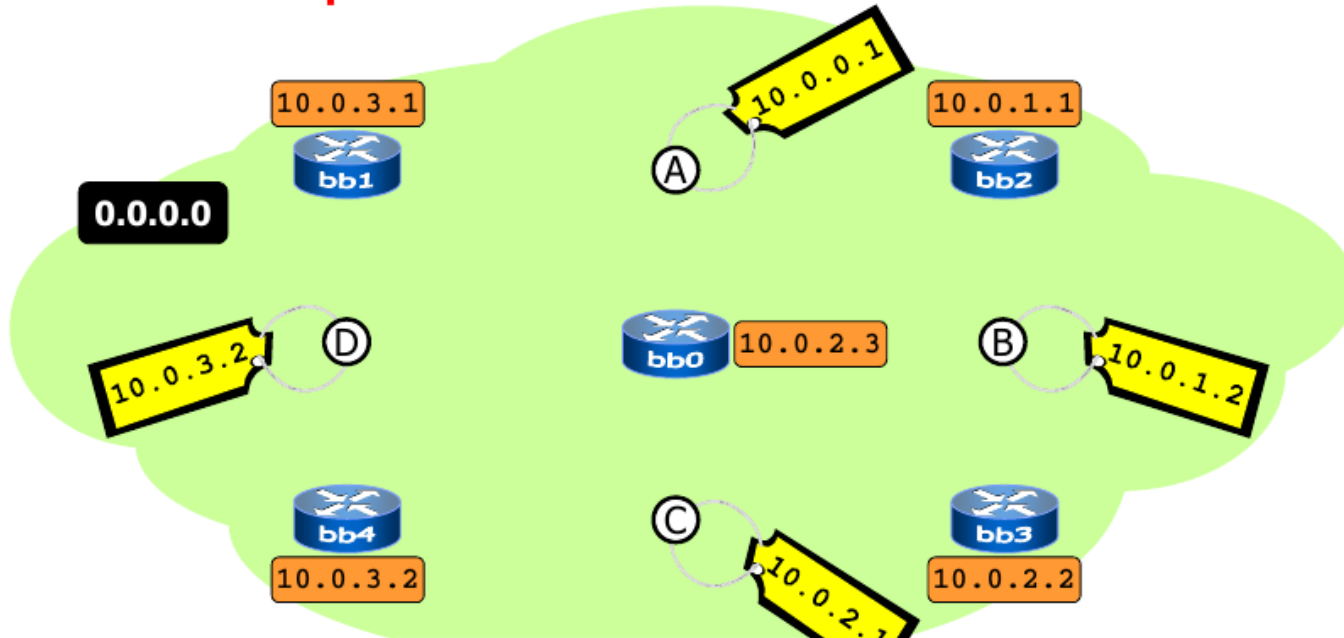

```
bb0
bb0# show ip ospf database router
Link State ID: 10.0.1.1
Number of Links: 2
Link connected to: a Transit Network
(Link ID) Designated Router address: 10.0.0.1
(Link Data) Router Interface address: 10.0.0.2
Link connected to: a Transit Network
(Link ID) Designated Router address: 10.0.1.2
(Link Data) Router Interface address: 10.0.1.1
```

note: the output of show ip ospf database router has been summarized

last update: Nov 2014

ospf's view of the network

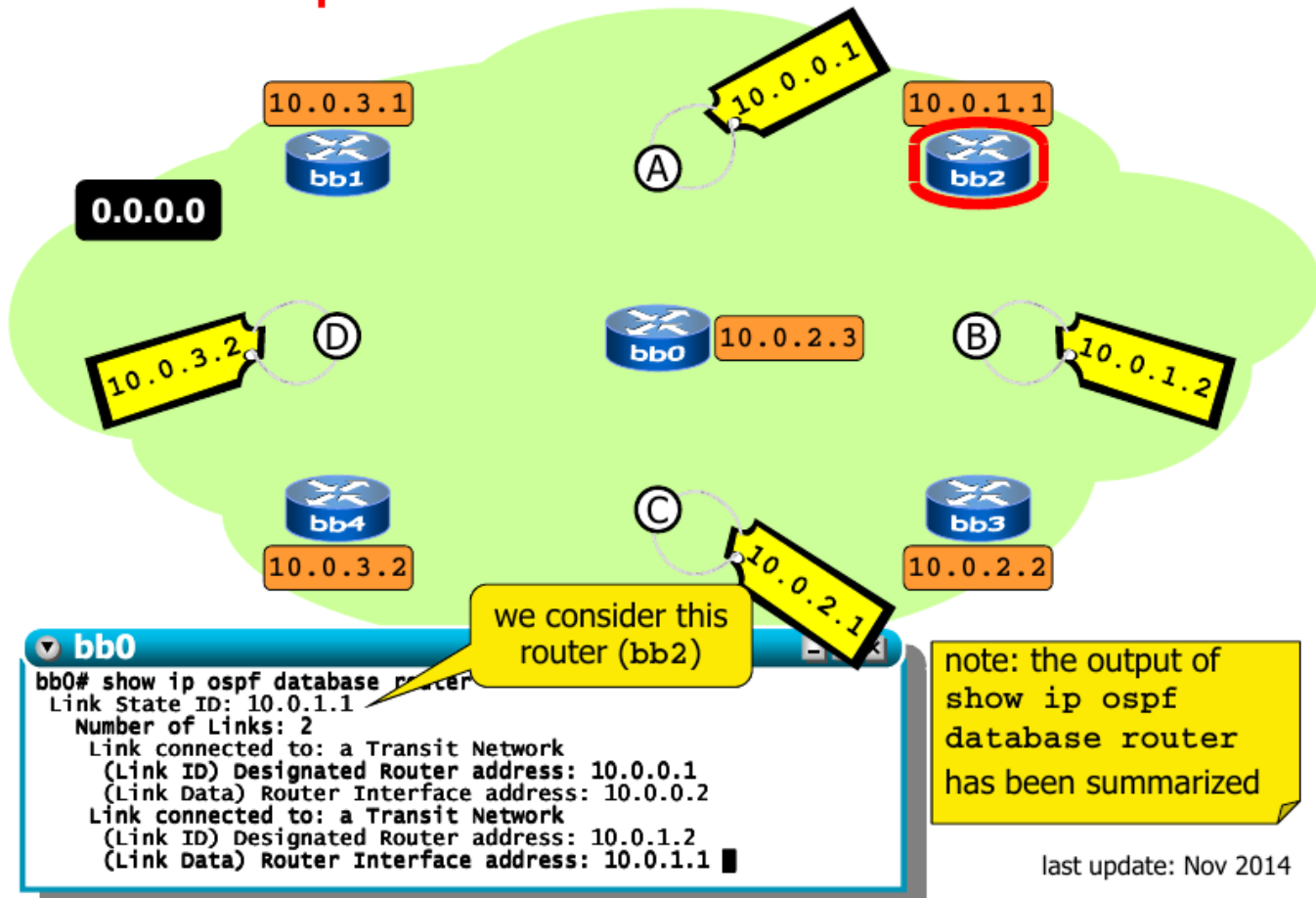

ospf's view of the network

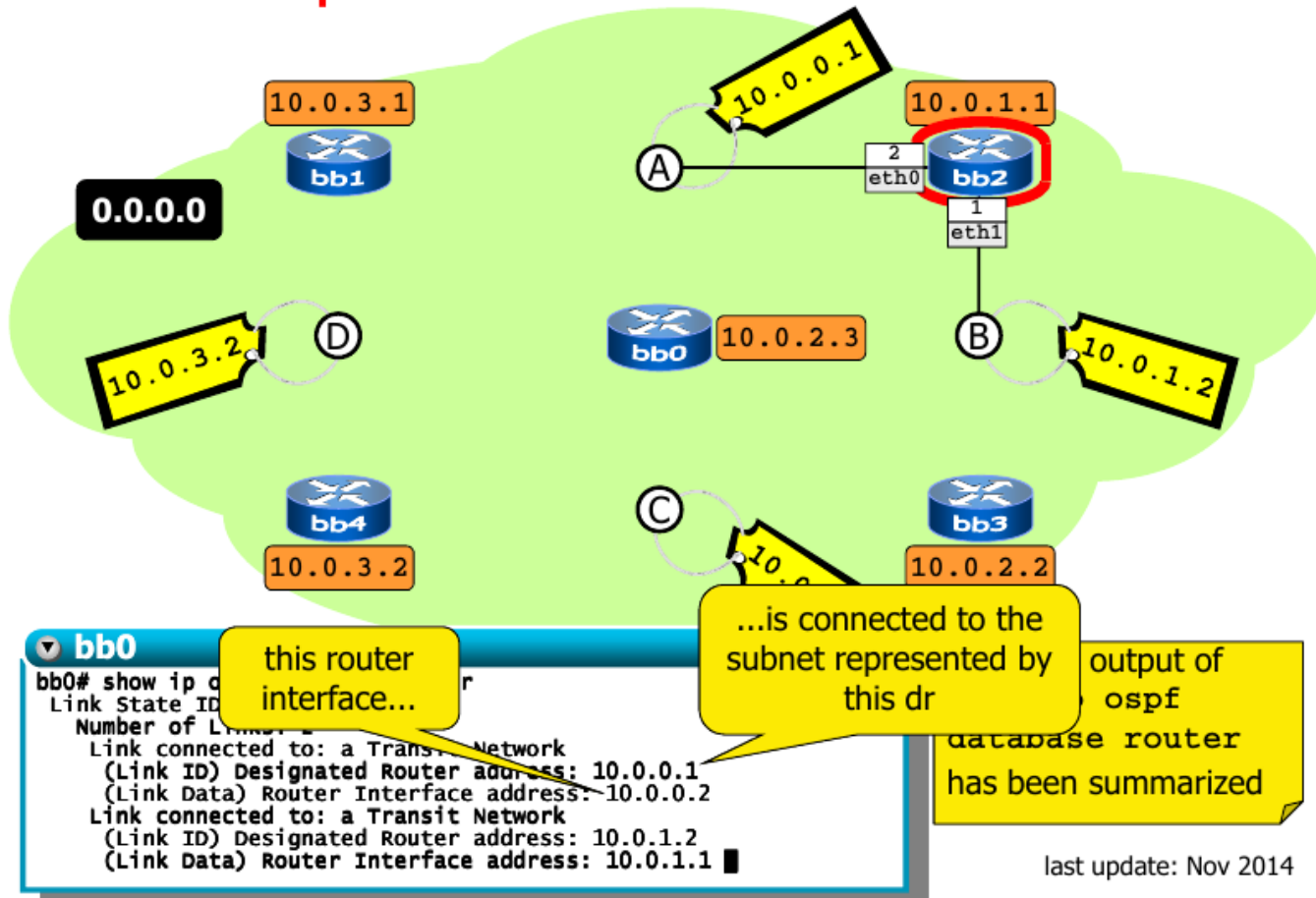

last update: Nov 2014

ospf's view of the network

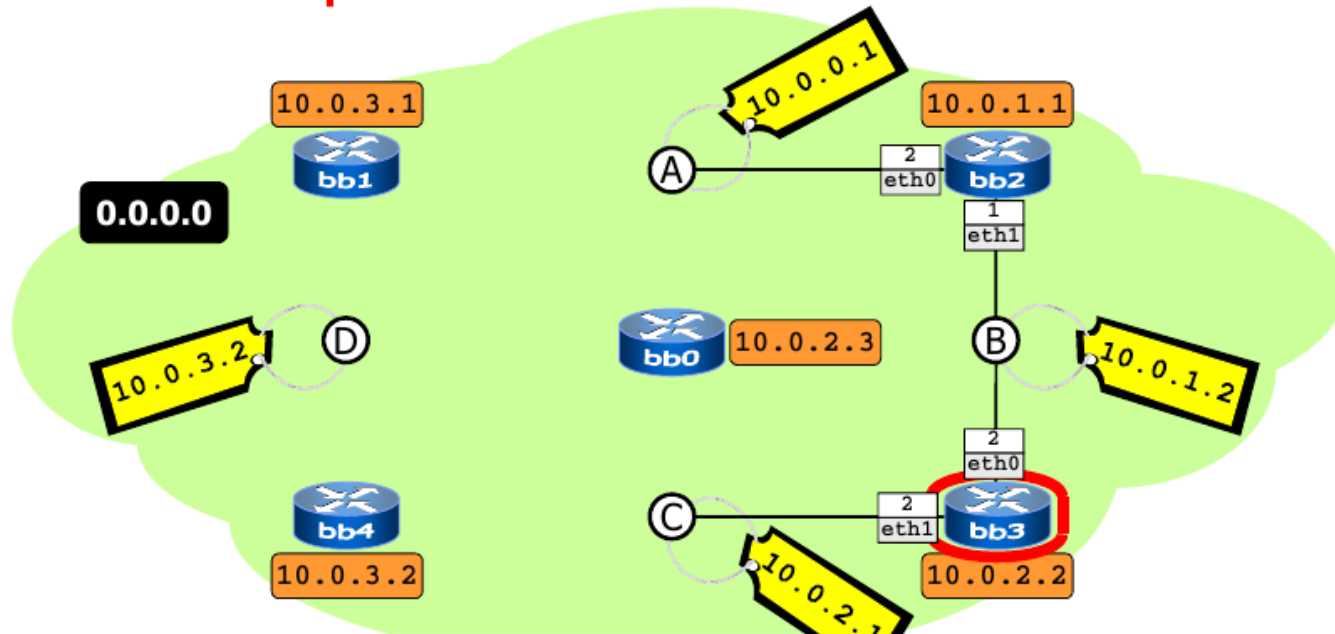

```
bb0
Link State ID: 10.0.2.2
Number of Links: 2
Link connected to: a Transit Network
(Link ID) Designated Router address: 10.0.1.2
(Link Data) Router Interface address: 10.0.1.2
Link connected to: a Transit Network
(Link ID) Designated Router address: 10.0.2.1
(Link Data) Router Interface address: 10.0.2.2
```

note: the output of show ip ospf database router has been summarized

router legnagyobb IP címe

last update: Nov 2014

ospf's view of the network

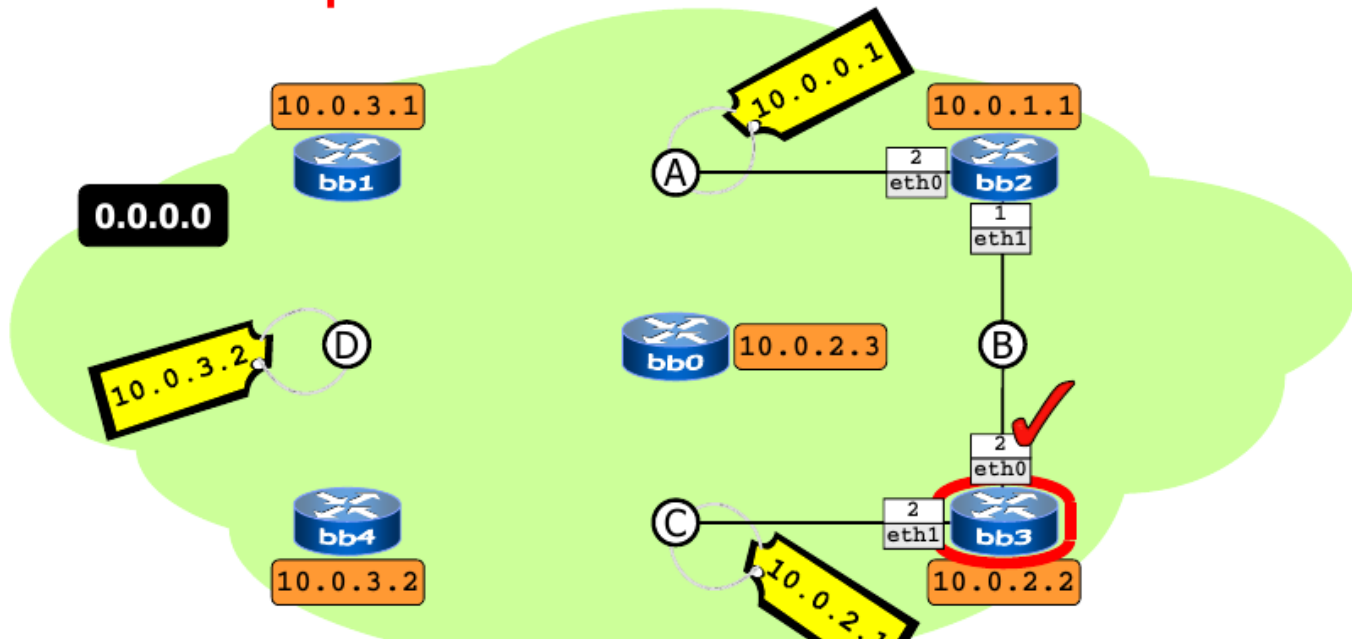

```
bb0
Link State ID: 10.0.2.2
Number of Links: 2
Link connected to: a Transit Network
(Link ID) Designated Router address: 10.0.1.2
(Link Data) Router Interface address: 10.0.1.2
Link connected to: a Transit Network
(Link ID) Designated Router address: 10.0.2.1
(Link Data) Router Interface address: 10.0.2.2
```

note: the output of show ip ospf database router has been summarized

last update: Nov 2014



ospf's view of the network

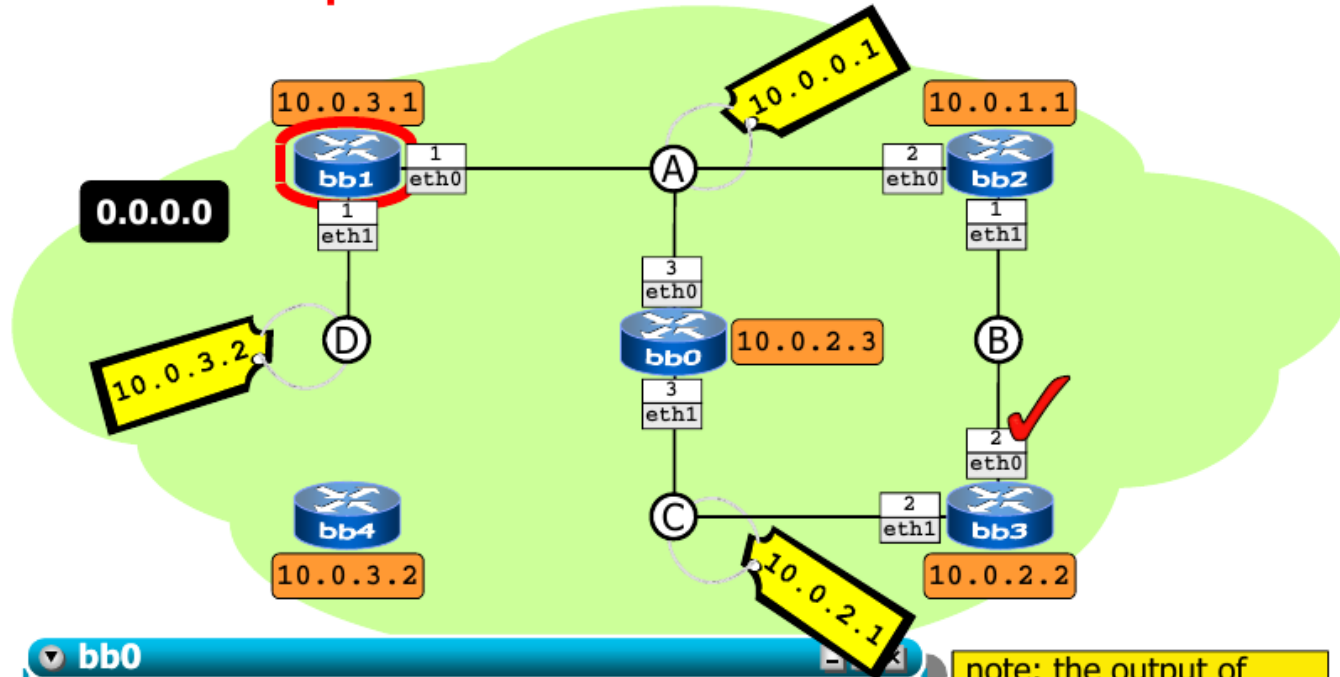

```
bb0
Link State ID: 10.0.3.1
Number of Links: 2
Link connected to: a Transit Network
(Link ID) Designated Router address: 10.0.0.1
(Link Data) Router Interface address: 10.0.0.1
Link connected to: a Transit Network
(Link ID) Designated Router address: 10.0.3.2
(Link Data) Router Interface address: 10.0.3.1
```

note: the output of show ip ospf database router has been summarized

last update: Nov 2014

ospf's view of the network

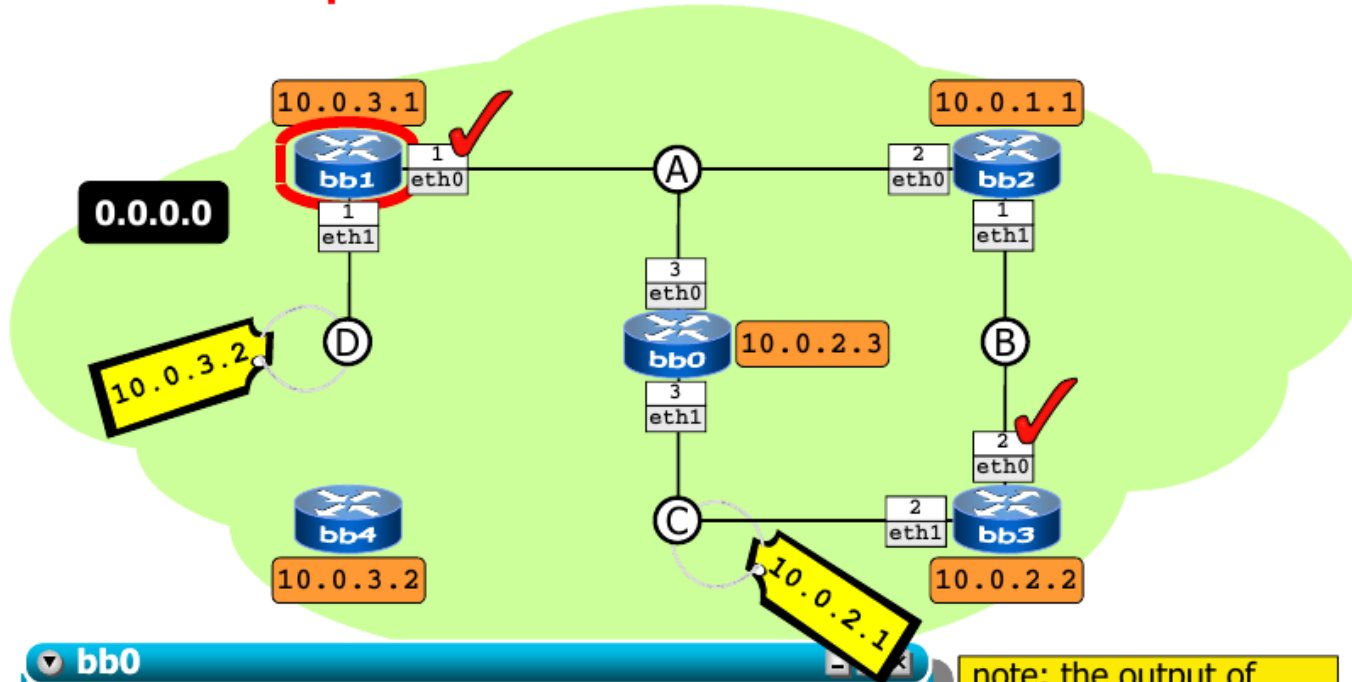

```
bb0
Link State ID: 10.0.3.1
Number of Links: 2
Link connected to: a Transit Network
(Link ID) Designated Router address: 10.0.0.1
(Link Data) Router Interface address: 10.0.0.1
Link connected to: a Transit Network
(Link ID) Designated Router address: 10.0.3.2
(Link Data) Router Interface address: 10.0.3.1
```

note: the output of show ip ospf database router has been summarized

last update: Nov 2014

ospf's view of the network

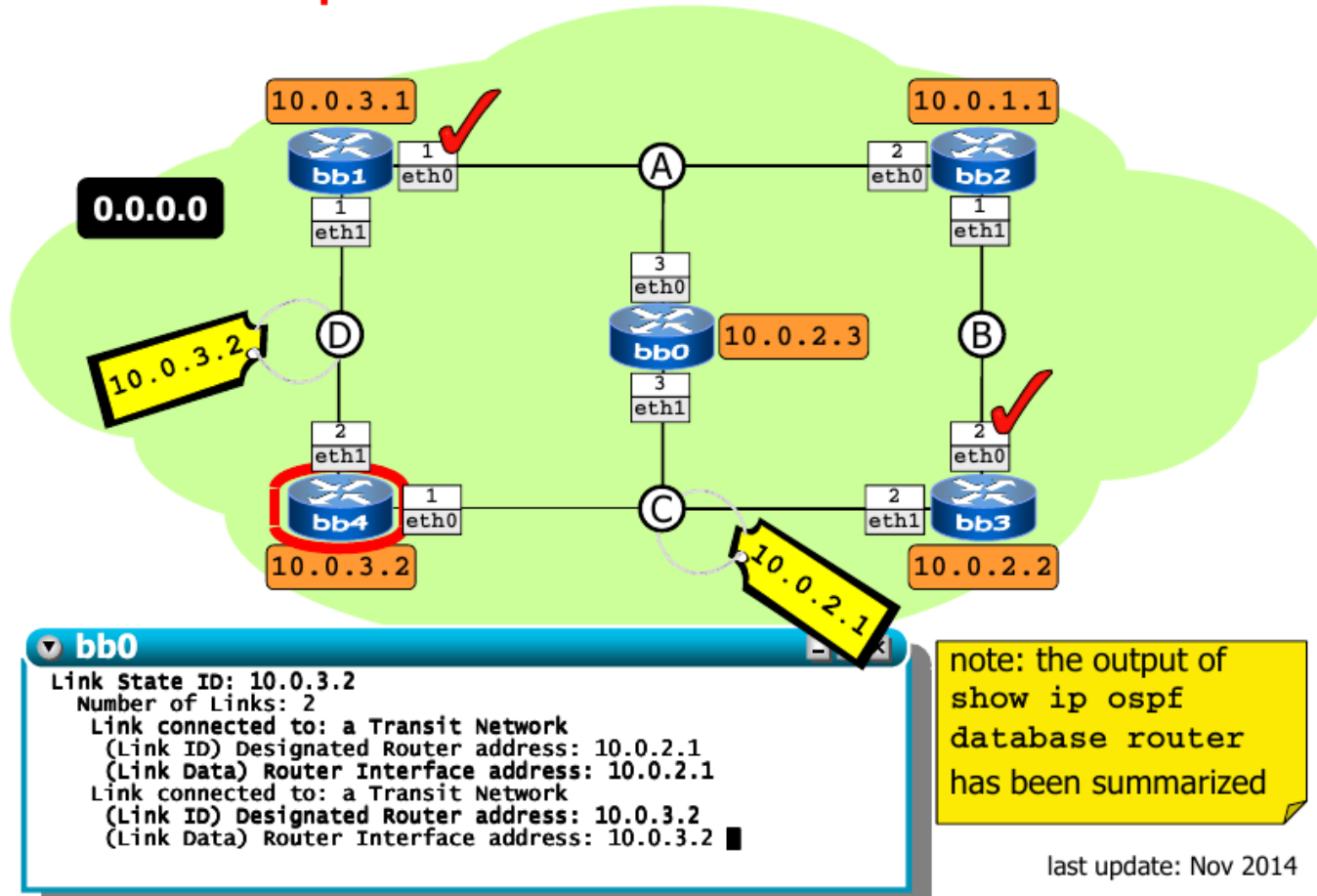

ospf's view of the network

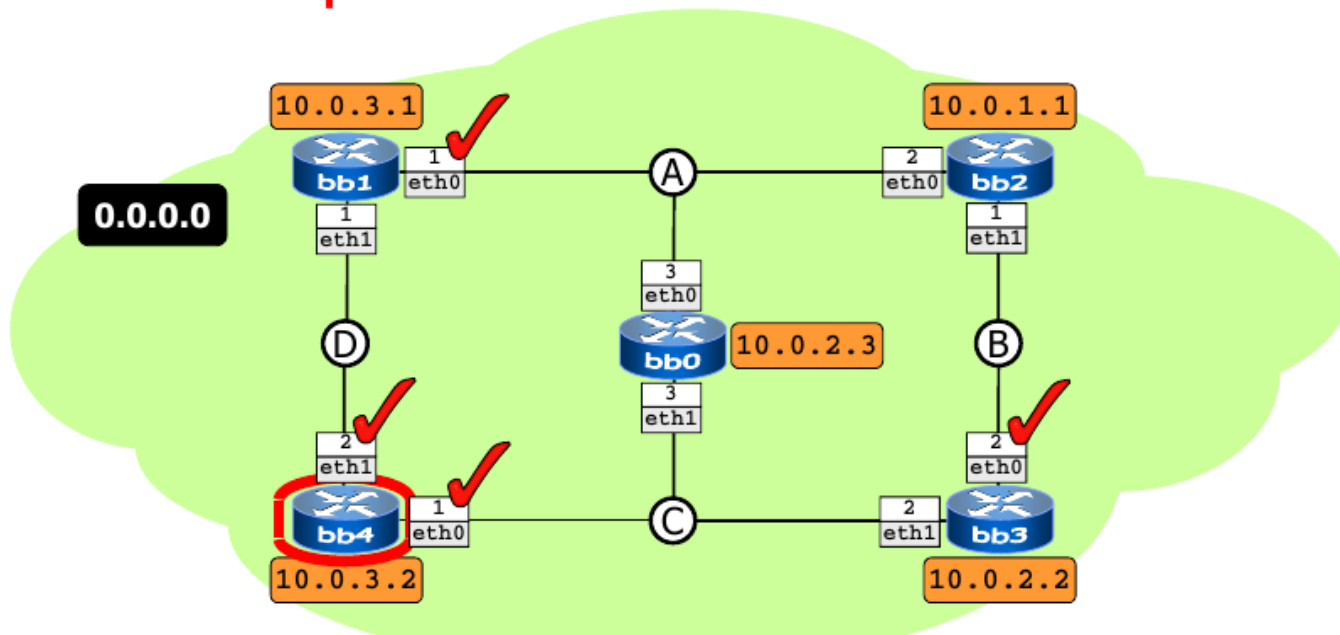

```
bb0
Link State ID: 10.0.3.2
Number of Links: 2
Link connected to: a Transit Network
(Link ID) Designated Router address: 10.0.2.1
(Link Data) Router Interface address: 10.0.2.1
Link connected to: a Transit Network
(Link ID) Designated Router address: 10.0.3.2
(Link Data) Router Interface address: 10.0.3.2
```

note: the output of show ip ospf database router has been summarized

last update: Nov 2014

ospf's view of the network

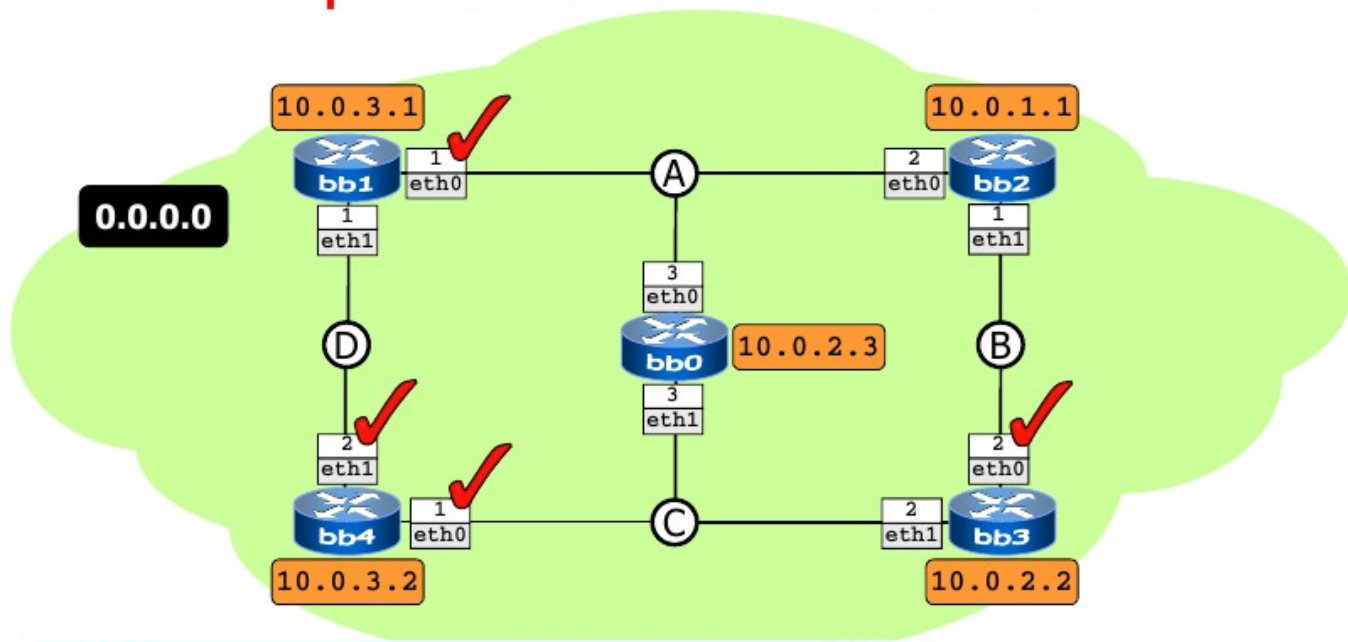

```
bb0  
bb0# show ip ospf database network █
```

ospf's view of the network

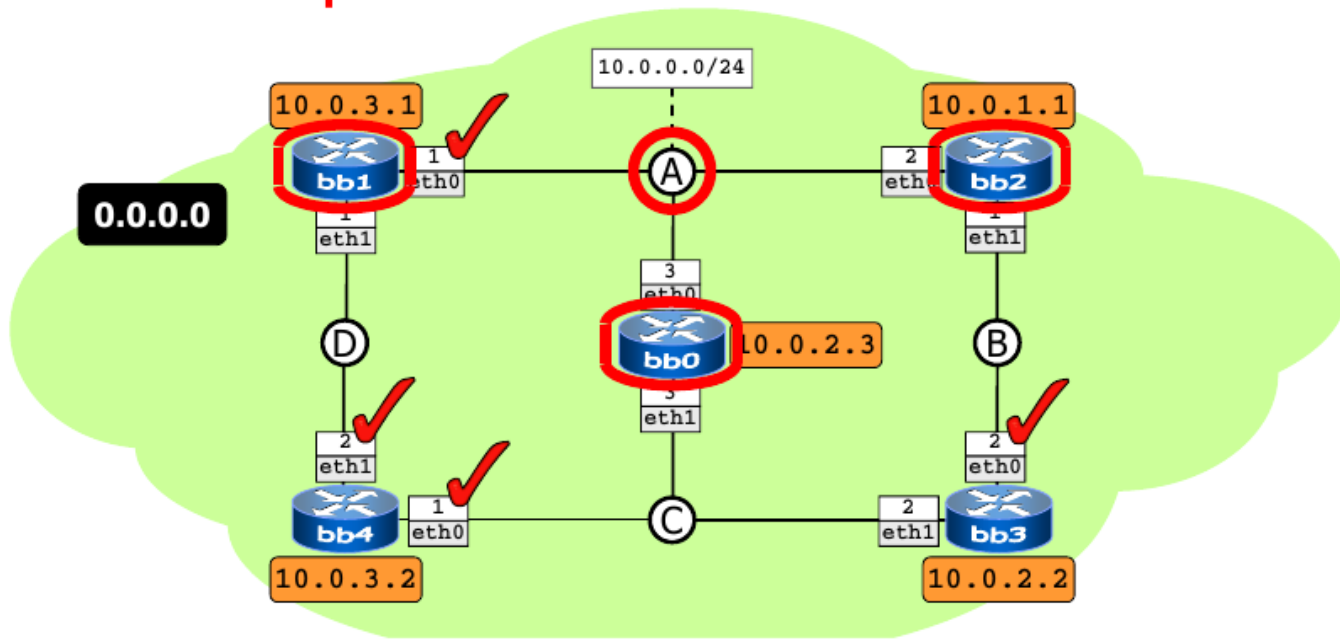

```
bb0
Link State ID: 10.0.0.1 (address of Designated Router)
Advertising Router: 10.0.3.1
Network Mask: /24
Attached Router: 10.0.3.1
Attached Router: 10.0.1.1
Attached Router: 10.0.2.3
```

note: the output of show ip ospf database network has been summarized

last update: Nov 2014

ospf's view of the network

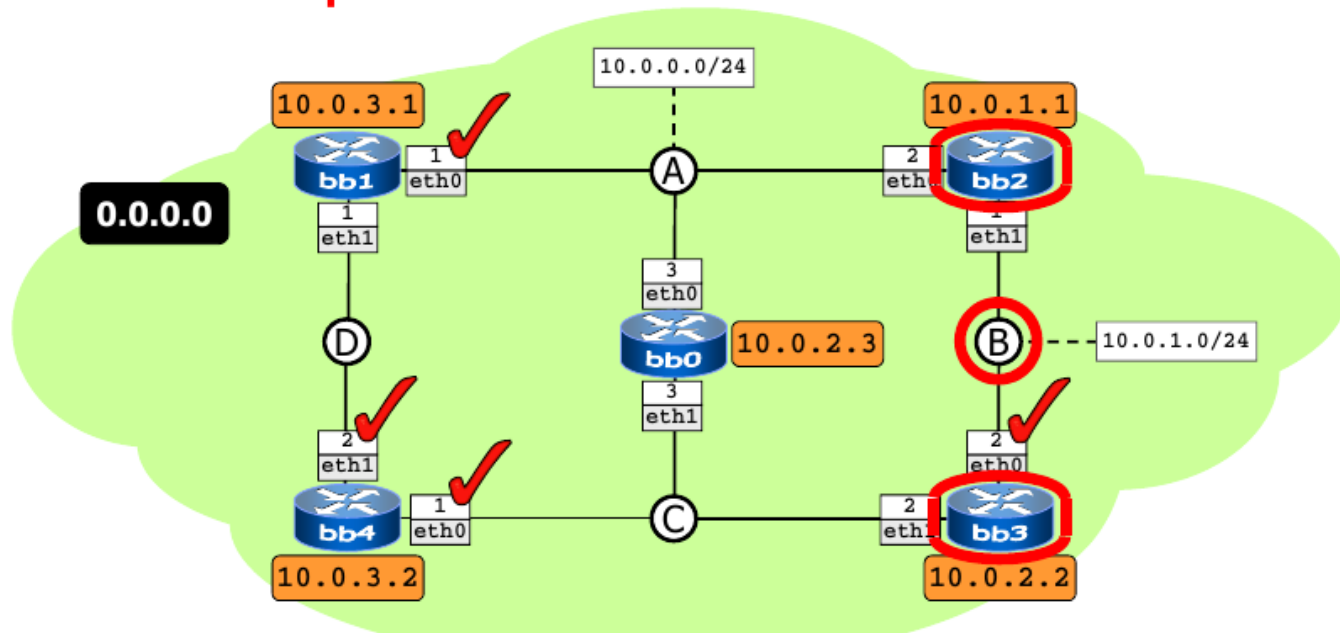

```
bb0
Link State ID: 10.0.1.2 (address of Designated Router)
Advertising Router: 10.0.2.2
Network Mask: /24
  Attached Router: 10.0.1.1
  Attached Router: 10.0.2.2
```

note: the output of show ip ospf database network has been summarized

last update: Nov 2014

ospf's view of the network

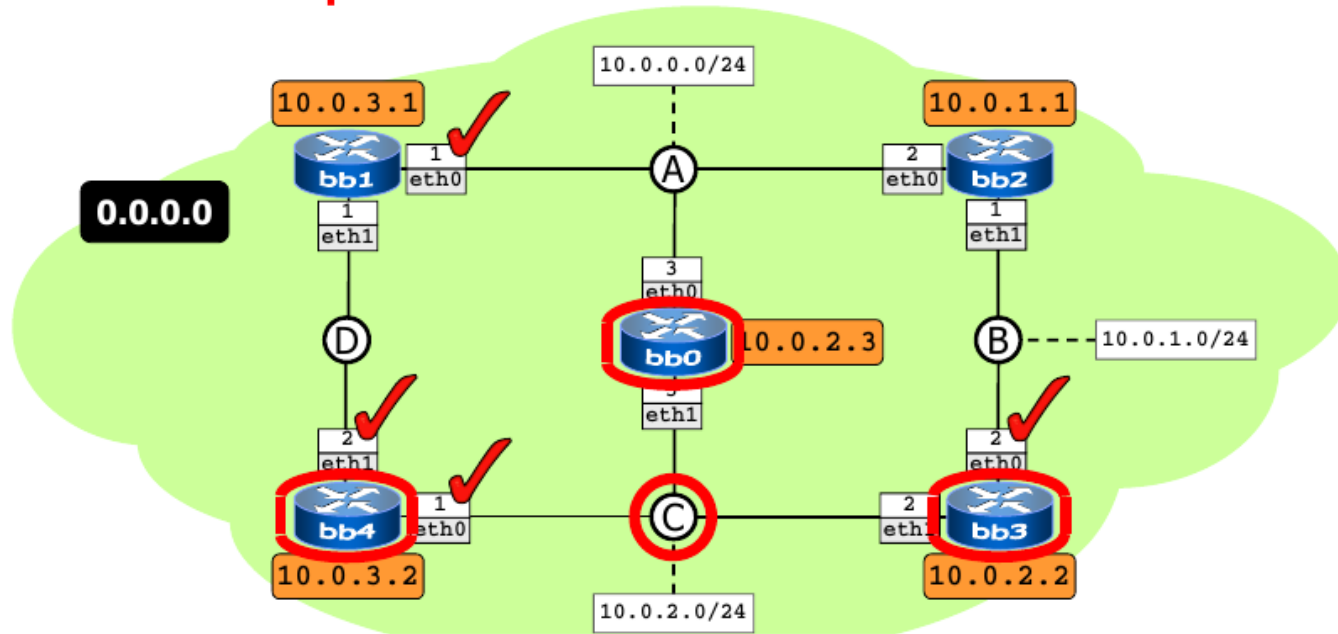

```
bb0
Link State ID: 10.0.2.1 (address of Designated Router)
Advertising Router: 10.0.3.2
Network Mask: /24
  Attached Router: 10.0.3.2
  Attached Router: 10.0.2.2
  Attached Router: 10.0.2.3
```

note: the output of show ip ospf database network has been summarized

last update: Nov 2014

ospf's view of the network

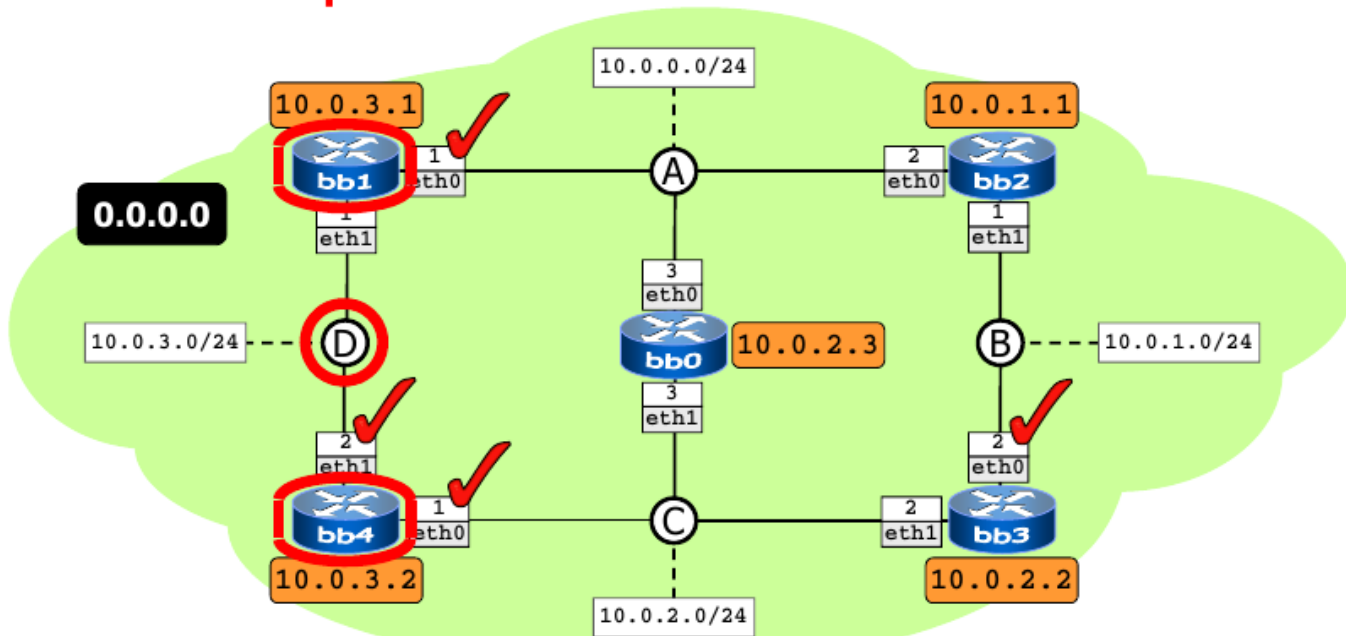

```
bb0
Link State ID: 10.0.3.2 (address of Designated Router)
Advertising Router: 10.0.3.2
Network Mask: /24
Attached Router: 10.0.3.1
Attached Router: 10.0.3.2
```

note: the output of show ip ospf database network has been summarized

last update: Nov 2014

ospf's view of the network

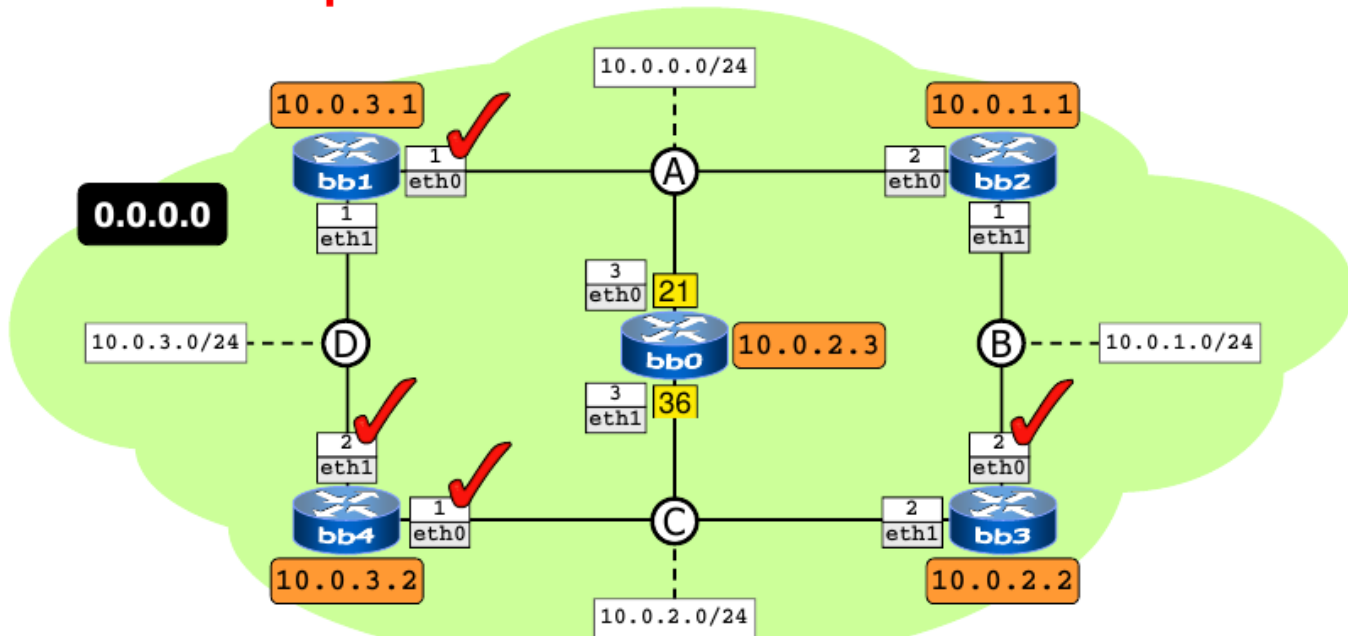

```
bb0
bb0:~# vtysh -e "show ip ospf interface" | egrep "eth|Cost"
eth0 is up
  Router ID 10.0.2.3, Network Type BROADCAST, Cost: 21
eth1 is up
  Router ID 10.0.2.3, Network Type BROADCAST, Cost: 36
```

a shortcut to quickly get the cost

ospf interface costs can be queried on all routers

Dinamikus működés

- ▶ OSPF üzenetek (Hello, majd LSA-k)
- ▶ Mi történik, ha lemegy egy link?
- ▶ Mi történik, ha lemegy egy DR link?
- ▶ Mi történik, ha lemegy egy router?

1. feladat: Router kommunikáció

- ▶ OSPF Hello üzenetek, később LSA-k
 - ▶ tcpdump -ne ip proto ospf
 - ▶ (esetleg -vv a részletes nézethez)
 - ▶ vizsgáljuk meg részletesebben
 - ▶ (később is érdemes pl. az egyik routeren futtatni)

2. feladat: link kiesése

- ▶ Mi történik, ha lemegy egy link?
 - ▶ ifconfig vagy ip parancs használható
 - ▶ pl. BB3 eth1 interfész down
 - ▶ hogy változnak az útvonalak?
 - ▶ pl. BB1-ről → 10.0.2.1 felé
 - traceroute -l icmp 10.0.2.1
 - ▶ routing táblák vizsgálata
 - show ip ospf route
 - ▶ kapcsoljuk vissza az interfészt

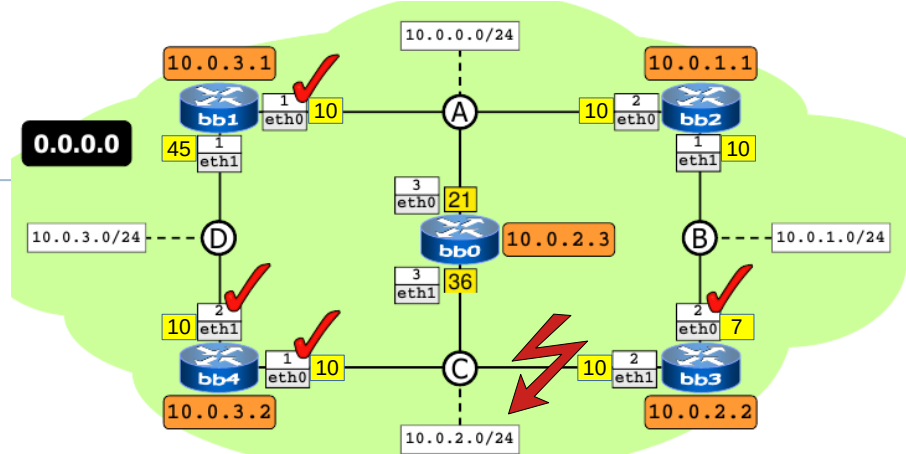

2. feladat: link kiesése

- ▶ Mi történik, ha lemegy egy link?

- ▶ ifconfig vagy ip parancs használható
- ▶ pl. BB3 eth1 interfész down
- ▶ hogy változnak az útvonalak?
 - ▶ pl. BB1-ről → 10.0.2.1 felé
 - traceroute -l icmp 10.0.2.1
 - ▶ routing táblák vizsgálata
 - show ip ospf route

- ▶ kapcsoljuk vissza az interfészt

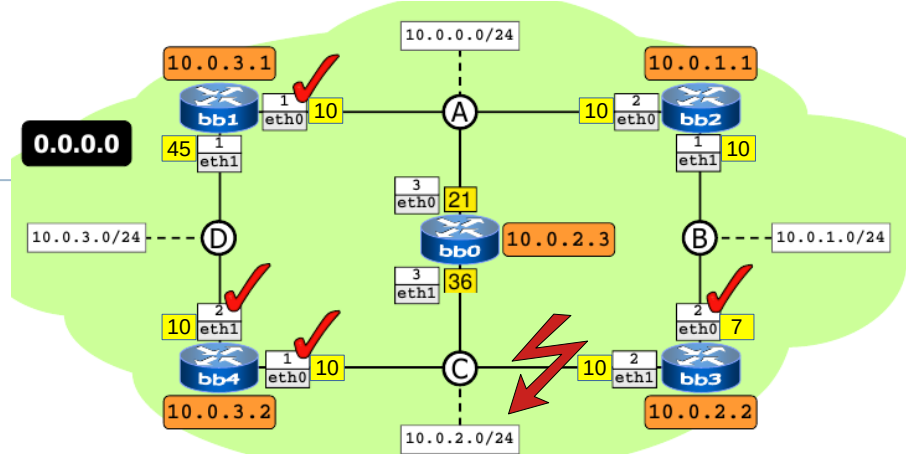

```
bb1:~# traceroute 10.0.2.1
traceroute to 10.0.2.1 (10.0.2.1), 64 hops max, 40 byte packets
 1 10.0.0.3 (10.0.0.3) 9 ms 1 ms 1 ms
 2 10.0.2.1 (10.0.2.1) 13 ms 2 ms 0 ms
```

```
bb1# sho ip route
Codes: K - kernel route, C - connected, S - static, R - RIP, O - OSPF,
       I - ISIS, B - BGP, > - selected route, * - FIB route

O 10.0.0.0/24 [110/10] is directly connected, eth0, 00:20:30
C>* 10.0.0.0/24 is directly connected, eth0
D>* 10.0.1.0/24 [110/20] via 10.0.0.2, eth0, 00:19:37
D>* 10.0.2.0/24 [110/46] via 10.0.0.3, eth0, 00:01:17
O 10.0.3.0/24 [110/45] is directly connected, eth1, 00:01:17
C>* 10.0.3.0/24 is directly connected, eth1
C>* 127.0.0.0/8 is directly connected, lo
```

3a. feladat: DR link kiesése

- ▶ Mi történik, ha DR link megy le?
 - ▶ pl. BB1 eth0 down
 - ▶ BB4-en router kommunikáció figyelése
 - tcpdump -ne ip proto ospf
 - ▶ BB2-n ospfd logok figyelése
 - tail -f /var/log/quagga/ospfd.log
 - ▶ BB0-n OSPF database ellenőrzése
 - show ip ospf database
 - ▶ BB1-en útvonalak ellenőrzése
 - BB1 eléri a 10.0.0.0 hálózatot?
 - mi történt?
 - ▶ BB1-en húzzuk vissza az eth0 interfészt
 - ▶ mindent vizsgáljunk újra

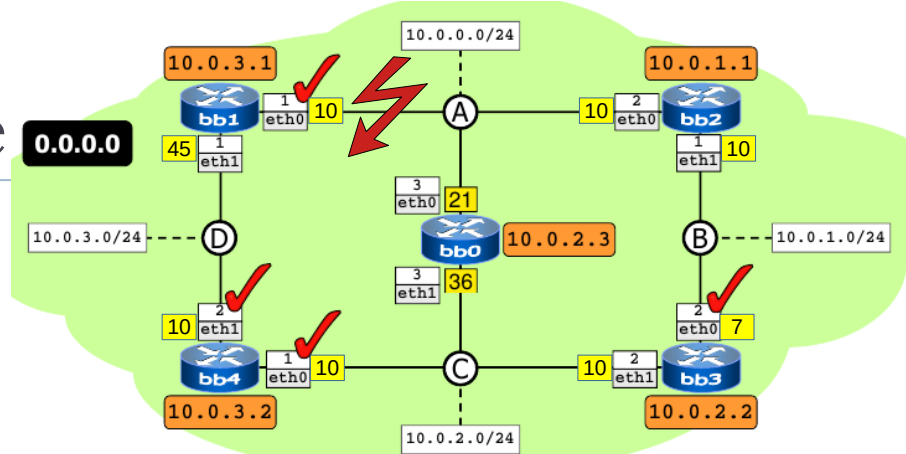

3a. feladat: DR link kiesése

▶ Mi történik, ha DR link megy le?

- ▶ pl. BB1 eth0 down
 - ▶ BB4-en router kommunikáció figyelése
 - tcpdump -ne ip proto ospf
 - ▶ BB2-n ospfd logok figyelése
 - tail -f /var/log/quagga/ospfd.log
 - ▶ BB0-n OSPF database ellenőrzése
 - show ip ospf database
 - ▶ BB1-en útvonalak ellenőrzése
 - BB1 eléri a 10.0.0.0 hálózati címet?
 - mi történt?
- ▶ BB1-en húzzuk vissza az eth0 linket
 - ▶ mindent vizsgáljunk újra

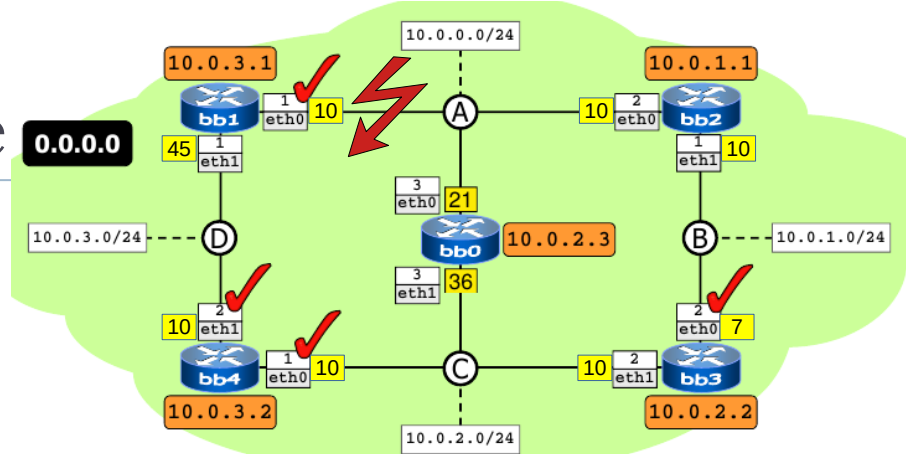

Új DR választása:

```
2021/11/09 01:00:43 OSPF: Link State Update[Type2,id(10.0.0,1),ar(10.0.3,1)]; LS age is equal to MaxAge.
2021/11/09 01:00:43 OSPF: Link State Update[Type2,id(10.0.0,1),ar(10.0.3,1)]; LS age is equal to MaxAge.
2021/11/09 01:01:13 OSPF: nsm_change_state(10.0.3,1, Full -> Deleted): scheduling new router-LSA origina
tion
2021/11/09 01:01:13 OSPF: DR-Election[1st]: Backup 10.0.0,3
2021/11/09 01:01:13 OSPF: DR-Election[1st]: DR 10.0.0,3
2021/11/09 01:01:23 OSPF: DR-Election[1st]: Backup 10.0.0,2
2021/11/09 01:01:23 OSPF: DR-Election[1st]: DR 10.0.0,3
2021/11/09 01:01:23 OSPF: DR-Election[2nd]: Backup 10.0.0,2
2021/11/09 01:01:23 OSPF: DR-Election[2nd]: DR 10.0.0,3
2021/11/09 01:01:23 OSPF: ospfTrapIFStateChange trap sent: 10.0.0,2 now Backup
2021/11/09 01:01:23 OSPF: interface 10.0.0,2 [3] join ALLSPF-neighbors Multicast group.
2021/11/09 01:01:23 OSPF: DR-Election[1st]: Backup 10.0.0,2
2021/11/09 01:01:23 OSPF: DR-Election[1st]: DR 10.0.0,3
```

3a. feladat

Mi történt?

- ▶ pl. BB1-én
- ▶ BB4-én
- ▶ BB2-n
- ▶ BB0-n
- ▶ BB1-én
- ▶ mindegyik routeren

```
bb0# show ip ospf database

OSPF Router with ID (10.0.2.3)

Router Link States (Area 0.0.0.0)

Link ID      ADV Router   Age  Seq#       CkSum  Link count
10.0.1.1    10.0.1.1     492  0x8000000d 0xd505  2
10.0.2.2    10.0.2.2     485  0x8000000b 0xffd4  2
10.0.2.3    10.0.2.3     483  0x8000000d 0xffa9  2
10.0.3.1    10.0.3.1      5   0x8000000e 0xca14  1
10.0.3.2    10.0.3.2     479  0x8000000a 0x507d  2

Net Link States (Area 0.0.0.0)

Link ID      ADV Router   Age  Seq#       CkSum  Link count
10.0.1.2    10.0.2.2     497  0x80000008 0x5bc2  2
10.0.2.3    10.0.2.3     483  0x80000009 0x51b2  2
10.0.3.2    10.0.3.2     485  0x80000008 0x5dba  2

bb0#
bb0# show ip ospf database

OSPF Router with ID (10.0.2.3)

Router Link States (Area 0.0.0.0)

Link ID      ADV Router   Age  Seq#       CkSum  Link count
10.0.1.1    10.0.1.1      2   0x8000000f 0xe5f0  2
10.0.2.2    10.0.2.2     524  0x8000000b 0xffd4  2
10.0.2.3    10.0.2.3     10  0x8000000e 0x1294  2
10.0.3.1    10.0.3.1     45   0x8000000e 0xca14  1
10.0.3.2    10.0.3.2     518  0x8000000a 0x507d  2

Net Link States (Area 0.0.0.0)

Link ID      ADV Router   Age  Seq#       CkSum  Link count
10.0.0.3    10.0.2.3     10  0x80000001 0x72b0  2
10.0.1.2    10.0.2.2     536  0x80000008 0x5bc2  2
10.0.2.3    10.0.2.3     522  0x80000009 0x51b2  2
10.0.3.2    10.0.3.2     524  0x80000008 0x5dba  2

bb0#
```

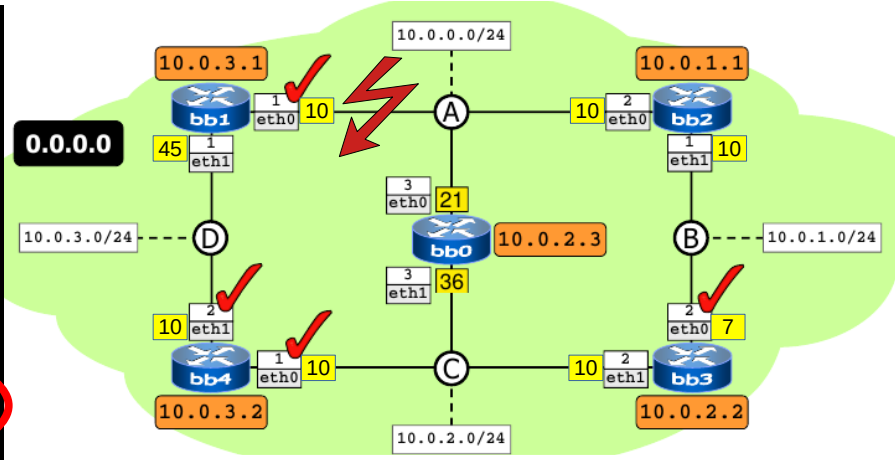

3a. feladat

- ▶ Mi történt?
- ▶ pl. BB1-én
- ▶ BB4-én
- ▶ BB2-n
- ▶ BB0-n
- ▶ BB1-én
- ▶ mindegyik

```
bb0# show ip ospf database

OSPF Router with ID (10.0.2,3)

Router Link States (Area 0.0.0.0)

Link ID      ADV Router   Age  Seq#       CkSum  Link count
10.0.1.1    10.0.1.1     492  0x8000000d 0xd505  2
10.0.2.2    10.0.2.2     485  0x8000000b 0xffd4  2
10.0.2.3    10.0.2.3     483  0x8000000d 0xffa9  2
10.0.3.1    10.0.3.1      5   0x8000000e 0xca14  1
10.0.3.2    10.0.3.2    479  0x8000000a 0x507d  2

Net Link States (Area 0.0.0.0)

Link ID      ADV Router   Age  Seq#       CkSum  Link count
10.0.1.2    10.0.2.2     497  0x80000008 0x5bc2  2
10.0.2.3    10.0.2.3     483  0x80000009 0x51b2  2
10.0.3.2    10.0.3.2     485  0x80000008 0x5dba  2

bb0#
bb0# show ip ospf database

OSPF Router with ID (10.0,2,3)

Router Link States (Area 0.0.0.0)

Link ID      ADV Router   Age  Seq#       CkSum  Link count
10.0.1.1    10.0.1.1      2   0x8000000f 0xe5f0  2
10.0.2.2    10.0.2.2     524  0x8000000b 0xffd4  2
10.0.2.3    10.0.2.3     10  0x8000000e 0x1294  2
10.0.3.1    10.0.3.1     45  0x8000000e 0xca14  1
10.0.3.2    10.0.3.2    518  0x8000000a 0x507d  2

Net Link States (Area 0.0.0.0)

Link ID      ADV Router   Age  Seq#       CkSum  Link count
10.0.0.3    10.0.2.3     10  0x80000001 0x72b0  2
10.0.1.2    10.0.2.2     536  0x80000008 0x5bc2  2
10.0.2.3    10.0.2.3     522  0x80000009 0x51b2  2
10.0.3.2    10.0.3.2     524  0x80000008 0x5dba  2

bb0#
```

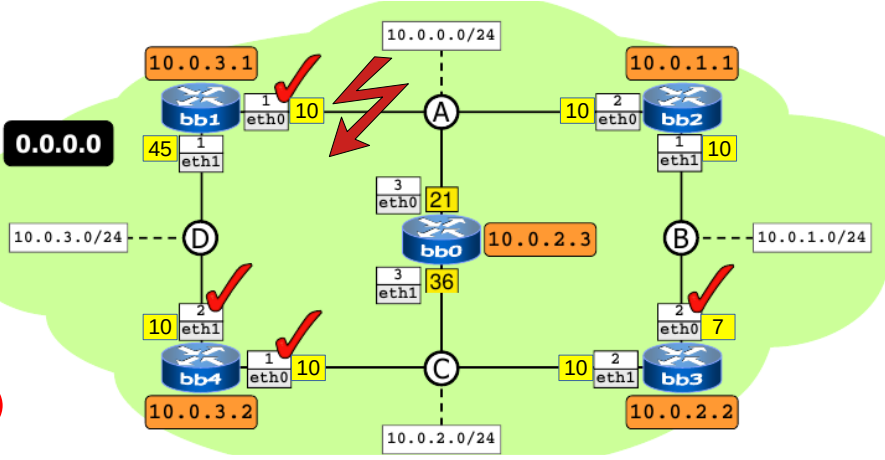

```
bb1# show ip route
Codes: K - kernel route, C - connected, S - static, R - RIP, O - OSPF,
       I - ISIS, B - BGP, > - selected route, * - FIB route

O>* 10.0.1.0/24 [110/62] via 10.0.3.2, eth1, 00:00:17
O>* 10.0.2.0/24 [110/55] via 10.0.3.2, eth1, 00:00:17
O 10.0.3.0/24 [110/45] is directly connected, eth1, 00:00:17
C>* 10.0.3.0/24 is directly connected, eth1
C>* 127.0.0.0/8 is directly connected, lo

bb1#
bb1# show ip route
Codes: K - kernel route, C - connected, S - static, R - RIP, O - OSPF,
       I - ISIS, B - BGP, > - selected route, * - FIB route

O>* 10.0.0.0/24 [110/72] via 10.0.3.2, eth1, 00:00:17
O>* 10.0.1.0/24 [110/62] via 10.0.3.2, eth1, 00:00:50
O>* 10.0.2.0/24 [110/55] via 10.0.3.2, eth1, 00:00:50
O 10.0.3.0/24 [110/45] is directly connected, eth1, 00:00:50
C>* 10.0.3.0/24 is directly connected, eth1
C>* 127.0.0.0/8 is directly connected, lo

bb1#
bb1#
```

3b. feladat: DR link kiesése

- ▶ Mi történik, ha DR link megy le?
 - ▶ pl. BB3 eth0 down
 - ▶ BB2-n ospfd logok figyelése
 - tcpdump -ne ip proto ospf
 - ▶ BB0-n OSPF interfészek és database figyelése
 - show ip ospf interface
 - show ip ospf database
 - ▶ BB3 eléri a 10.0.1.0 hálózatot?
 - ▶ mi történt a 10.0.1.0 hálózathoz tartozó “Net Link”-kel?
 - ▶ BB3-n húzzuk vissza az eth0 interfészt
 - ▶ mindent vizsgáljunk újra

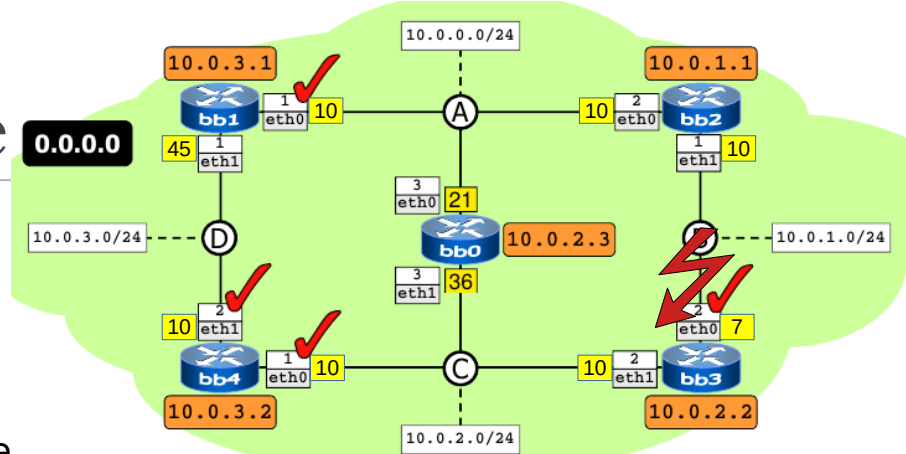

3b. feladat: DR link kiesése

- ▶ Mi történik, ha DR link megy le?
 - ▶ pl. BB3 eth0 down
 - ▶ BB2-n ospfd logok figyelése
 - tcpdump -ne ip proto ospf
 - ▶ BB0-n OSPF interfészek és database figyelése
 - show ip ospf interface
 - show ip ospf database
 - ▶ BB3 eléri a 10.0.1.0 hálózatot?
igen, 2 úton is, 40-es költségű lesz az aktív
 - ▶ mi történt a 10.0.1.0 hálózathoz tartozó “Net Link”-kel?

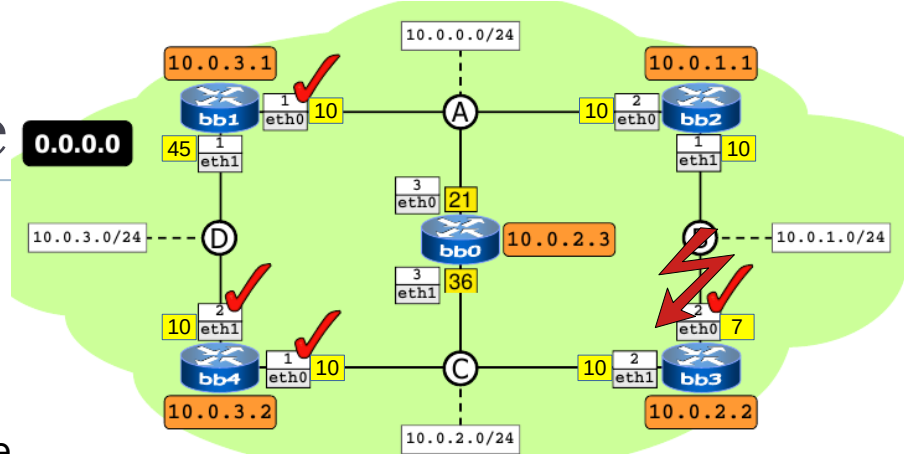

```
bb3# show ip route
Codes: K - kernel route, C - connected, S - static, R - RIP, O - OSPF,
       I - ISIS, B - BGP, > - selected route, * - FIB route

O>* 10.0.0.0/24 [110/30] via 10.0.2.1, eth1, 00:01:03
O>* 10.0.1.0/24 [110/40] via 10.0.2.1, eth1, 00:00:29
O 10.0.2.0/24 [110/10] is directly connected, eth1, 04:59:29
C>* 10.0.2.0/24 is directly connected, eth1
O>* 10.0.3.0/24 [110/20] via 10.0.2.1, eth1, 04:58:33
C>* 127.0.0.0/8 is directly connected, lo
bb3#
```

- ▶ BB3-n húzzuk vissza az eth0 interfészt
 - ▶ mindent vizsgáljunk újra

3b.

▶ Mi

▶ p

▶

▶

▶

```

bb0# show ip ospf database router 10.0.1.1

      OSPF Router with ID (10.0.2.3)

      Router Link States (Area 0.0.0.0)

LS age: 137
Options: 0x2 : *|I|I|I|I|IEI*
LS Flags: 0x6
Flags: 0x2 : ASBR
LS Type: router-LSA
Link State ID: 10.0.1.1
Advertising Router: 10.0.1.1
LS Seq Number: 80000019
Checksum: 0x9249
Length: 48
Number of Links: 2

Link connected to: a Transit Network
(Link ID) Designated Router address: 10.0.0.1
(Link Data) Router Interface address: 10.0.0.2
Number of TOS metrics: 0
TOS 0 Metric: 10

Link connected to: Stub Network
(Link ID) Net: 10.0.1.0
(Link Data) Network Mask: 255.255.255.0
Number of TOS metrics: 0
TOS 0 Metric: 10

```

k kiesése

egy le?

ospf

tabase figyelése

e

e

t?

ű lesz az aktív

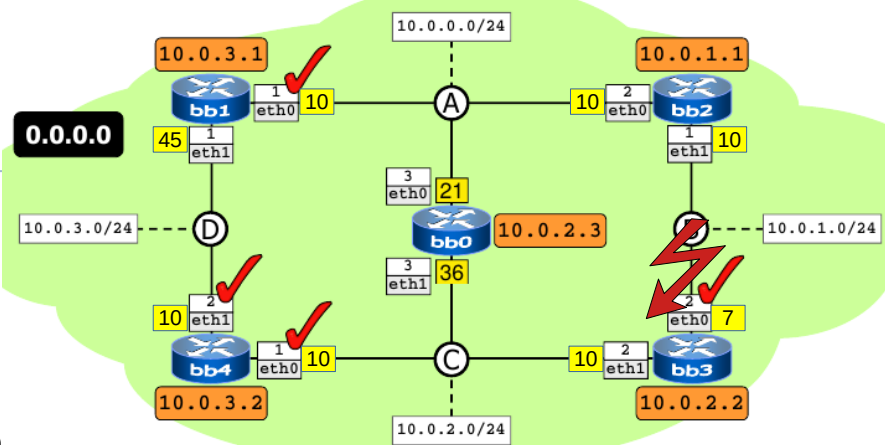

▶ mi történt a 10.0.1.0 hálózathoz tartozó "Net Link"-kel?

stub network lesz (levél), nem jelenik meg külön, router-en keresztül "ismeri"

```

▶ Net Link States (Area 0.0.0.0)

Link ID      ADV Router    Age Seq#      CkSum
10.0.0.1    10.0.3.1     1261 0x80000002  0x69a9
10.0.2.3    10.0.2.3     1748 0x8000000b  0x4db4
10.0.3.2    10.0.3.2     1749 0x8000000a  0x59bc

```

```

2021/11/09 02:20:18 OSPF: Link State Update[Type2,id(10.0.1.2),ar(10.0.2.2)]: LS age is equal to MaxAge.
2021/11/09 02:20:18 OSPF: Link State Update[Type2,id(10.0.1.2),ar(10.0.2.2)]: LS age is equal to MaxAge.
2021/11/09 02:20:49 OSPF: nsm_change_state(10.0.2.2, Full -> Deleted): scheduling new router-LSA origina
tion
2021/11/09 02:20:49 OSPF: DR-Election[1st]: Backup 10.0.1.1
2021/11/09 02:20:49 OSPF: DR-Election[1st]: DR 10.0.1.1
2021/11/09 02:20:49 OSPF: DR-Election[2nd]: Backup 0.0.0.0
2021/11/09 02:20:49 OSPF: DR-Election[2nd]: DR 10.0.1.1
2021/11/09 02:20:49 OSPF: ospfTrapIfStateChange trap sent: 10.0.1.1 now DR

```

3b. feladat: DR link kiesése

- ▶ Mi történik, ha DR link megy le?
 - ▶ pl. BB3 eth0 down
 - ▶ BB2-n ospfd logok figyelése
 - tcpdump -ne ip proto ospf
 - ▶ BB0-n OSPF interfészek és database figyelése
 - show ip ospf interface
 - show ip ospf database
 - ▶ BB3 eléri a 10.0.1.0 hálózatot?
igen, 2 úton is, 40-es költségű lesz az aktív
 - ▶ mi történt a 10.0.1.0 hálózathoz tartozó “Net Link”-kel?
stub network lesz (levél), nem jelenik meg külön, router-en keresztül “ismeri”
 - ▶ BB3-n húzzuk vissza az eth0 interfészt
 - ▶ mindent vizsgáljunk újra

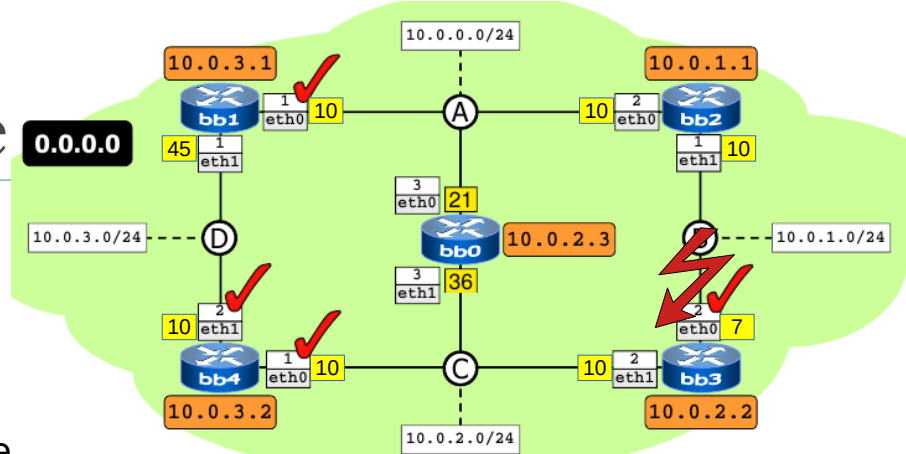

```
Net Link States (Area 0.0.0.0)
```

Link ID	ADV Router	Age	Seq#	CkSum
10.0.0.1	10.0.3.1	510	0x80000003	0x67aa
10.0.1.1	10.0.1.1	71	0x80000001	0x80a7
10.0.2.3	10.0.2.3	997	0x8000000c	0x4bb5
10.0.3.2	10.0.3.2	998	0x8000000b	0x57bd

```
eth1 is up
ifindex 4, MTU 1500 bytes, BW 0 Kbit <UP,BROADCAST,RUNNING,MULTICAST>
Internet Address 10.0.1.1/24, Broadcast 10.0.1.255, Area 0.0.0.0
MTU mismatch detection:enabled
Router ID 10.0.1.1, Network Type BROADCAST, Cost: 10
Transmit Delay is 1 sec, State DR, Priority 1
Designated Router (ID) 10.0.1.1, Interface Address 10.0.1.1
Backup Designated Router (ID) 10.0.2.2, Interface Address 10.0.1.2
Multicast group memberships: OSPFAllRouters OSPFDesignatedRouters
Timer intervals configured, Hello 10s, Dead 40s, Wait 40s, Retransmit 5
Hello due in 1,600s
Neighbor Count is 1, Adjacent neighbor count is 1
```

4. feladat: router kiesése

- ▶ Mi történik, ha lemegy egy router?
 - ▶ pl. minden interfészt down állapotba kapcsoljuk
 - ▶ házi feladat